



Effect of Visionary Leadership on Team Innovation: Understanding Mediating Roles of Team Cohesion, Team Knowledge Collaboration and Team Boundary Management

Wahyu Abdillah Utomo^{1*}, Heru Kurnianto Tjahjono², Ika Nurul Qamari³

¹Department of Doctoral Management, Universitas Muhammadiyah Yogyakarta, Yogyakarta, Indonesia; wahyu.abdillah.psc21@mail.umy.ac.id (W.A.U.) herukurnianto@umy.ac.id (H.K.T.) ika_nr@umy.ac.id (I.N.Q.).

Abstract. This study is important as it seeks to fill the existing gap in the existing literature on the interactions between visionary leadership and team innovation in the context of the palm oil industry which is confronted with the challenge of achieving profitability while operating in an environmentally sustainable manner. The study sets out to investigate the impact of visionary leadership on the innovation exhibited by the teams while focusing on team cohesion, team knowledge collaboration and team boundary management as the mediating variables. A quantitative explanatory design was adopted and data was collected from 280 respondents in nine palm oil factories in Rokan Hulu Re-gency, Riau Province, Indonesia. Databases include Structural Equation Modeling (SEM) Managed to achieve data processing and analysis of the relationships among the variables. The results show that anyway, visionary leadership is a strong contributor to team innovation, both directly and indirectly, through its principles such as teamwork, boundary management, and even collaboration. From these findings, it is critical to highlight that visionary leadership is key in enhancing the team work environment and the team collaboration potential which in the long run triggers innovation. Such management practices should focus on how to develop leadership that drives sharing of knowledge and boundary management as this improves the innovation capabilities of the firm.

Keywords: Leadership, Palm Oil Industry, SEM, Team Management.

1. INTRODUCTION

A clear understanding of the importance of cooperation and creative ability between team members should be maintained for the success of the organization. New ideas are essential in design, and the implementation of these ideas will definitely improve team performance. (Hughes et al., 2018). Both innovation and creativity lead to an enhanced performance of the team as well as boost the enthusiasm and job satisfaction of the members. If team members know that their ideas would most likely be listened to, they will most probably be willing to venture out and explore more ideas (Grass et al., 2020). For example, creativity and innovation are the significant ingredients for teams to ensure sustainability and success by being able to solve their problem creatively and adapt to the changing market (Oh & Choi, 2020). Success requires adaptability and resilience of leadership within fluctuating challenges of a company's environment (Madi Odeh et al., 2023).

The effective leader empowers and motivates a team to achieve a lofty vision that represents the goals shared among the members. They also provide motivational support that will make each of the team members feel appreciated and motivated to give their fullest output (Ronald & Marc, 2021). As Ronald & Marc, 2021, argue, it is also required for leaders to have the appropriate communication skills to articulate the vision, strategy and objectives of the team (Mascareño et al., 2020). This will involve strategy formulation, decision-making, team empowerment, coaching, and conflict management foundational in ensuring effective performance of the team (Aslam, 2020).

Leadership is known to be one of factors in increasing the creativity and also the innovation of employees because the leaders are able to build a good atmosphere of work, allocating good resources and leading the team members (Anderson et al., 2014); Jensen et al., 2019); Rosing et al., 2011); Jantz, 2017). Transactional leadership builds the foundation of the relationship between leaders and followers by determining expectations, explaining responsibilities, negotiating agreements, and providing recognition and appreciation for achieving expected performance (Thahira et al., 2020). On the other hand, a transformational leadership style also aims to inspire and motivate individuals to go beyond personal interests and commit to common goals (Tjahjono et al., 2018). Transformational leaders provide direction, instill a long-term vision, and boost employee morale to feel valued and motivated to contribute more (Mikhriani et al., 2021). One leadership style that really encourages innovation is visionary leadership. Visionary leadership, defined as verbal communication about a collective's future image, aims to convince others to contribute to realizing that future (Knippenberg & Stam, 2014).

Of the many, visionary leadership is one of the most highly recognized leadership styles in dynamic and fast-changing environments. While multiple types of leadership styles may facilitate a team in terms of getting successful results, visionary leadership is better suited to the industry where changes are continuous, happening without knowing when it may happen; it depends on the long term vision and adaptability. A visionary leader "communicates a vision to inspire and direct others in pursuit of organization success while encouraging collective effort (Bunnoiko & Atthirawong, 2017; Kearney et al., 2019; Knippenberg & Stam, 2014). Recent studies identified that Visionary Leadership was positively related to team cohesion, boundary

management, innovation, and in particular that team cohesion mediates the relationship between leadership between leadership and team innovation (van der Voet & Steijn, 2021). This leadership style also proves to be key in retaining focus and cohesion in the middle of external changes and challenges.

Though internally providing cohesion is important, visionary leaders also need to look at external demands. Good management of boundaries is quite crucial for maintaining the development of relationship with various external stakeholders that comprises supplies, governments, as well as society in general (Cinnioğlu, 2020; Maynard et al., 2015). These external relations improve operational efficiency, innovation, risk reduction, and finally long-term growth (Escher & Brzustewicz, 2020; Tarigan et al., 2021).

Therefore, the leadership skill of managing external relationships or Boundary-Spanning becomes most critical to ensure an organization's sustainability and success in these complex dynamic environments (Kim et al., 2022; Kou, 2021). Boundary-spanning also reinforces team cohesion in that it ensures that teams are not only internally aligned but also capable of engaging external stakeholders effectively.

For palm oil companies in Rokan Hulu, observation and interviews reveal that Visionary Leadership significantly influenced the various aspects of operations, the practice is included in those that are friendly to the environment and enhances global competitiveness; hence, it strikes a balance between economic growth and environmental protection. It is because of such leadership that companies use advanced technologies to enhance the production efficiency and minimize environmental degradation from their operations (Saif et al., 2022).

Moreover, far-sighted leaders promoted teamwork in technology to ignite innovative technology within the companies since the industry would continue to grapple with the pressure on sustainability and regulatory issues of the commodity.

Palm oil industry is quite peculiar and uniquely problematic in juggling rapid economic growth with environmental sustainability especially in Indonesia and Malaysia. While the global demand for palm oil is on the increase, there is a need for companies to innovate their way to attain higher productivity with minimal environmental destruction. In essence, visionary leadership therefore plays a very important role in guiding such external dynamics through companies, innovation sustainable practices, while maintaining the internal framework intact. Understanding how visionary leadership fosters team innovation is critical in developing an intervention focused on improving internal dynamics and greater environmental and regulatory challenges that are affecting it.

Despite the fast-increasing literature on leadership styles and innovation, there has been deficiency of empirical research considering mediation in team cohesion, knowledge collaboration, and boundary management in the palm oil industry. Mostly, the literature has focused on, for example, in social welfare, such as Voet and Steijn (2021), described that "little is known about how such dynamics play out in resource-economic industries like palm oil." While previous literature has emphasized boundary management as key to developing relations with external entities, little clarity exists as to how this plays itself out with regard to the innovation team in an industry where the close interaction with external regulators and sustainability of driven stakeholders. The struggle for the balance between environmental concerns and the goals of productivity in the palm oil industry entails more intensive explorations of how Visionary Leadership influences boundary-spanning practices in internal innovation and wider innovation ecosystems.

Team knowledge collaboration is considered essential as a key driver of innovation, especially when a team in an organization is led by a visionary leader (Leinonen, 2006). A visionary leader not only directs the team's vision and strategy but also creates an environment that encourages intensive knowledge collaboration (Richardson, 2017). Team knowledge collaboration refers to the process by which team members actively share, integrate, and apply knowledge to achieve common goals (Kao, 2019). This process involves combining multiple perspectives from individuals with different knowledge backgrounds and expertise (Hall et al., 2019). Effective knowledge collaboration is crucial because it allows team members to combine multiple perspectives and expertise, which can ultimately produce creative and innovative solutions (Ronald & Marc, 2021).

This research contributes uniquely to the literature by focusing on an industrial context, the palm oil industry, which faces big challenges in trying to balance environmental sustainability with economic growth. It introduces team cohesion, knowledge collaboration, and boundary-spanning practices as the mediating roles in assessing how Visionary Leadership drives innovation. Therefore, this research explores the intersection of leadership, internal team dynamics, and external pressures, offering a novel conceptual framework to better understand how visionary leadership influences innovation in heavily regulated and resource-intensive industries like palm oil.

2. METHODOLOGY

2.1. Research Design

This research employed a approach in quantitative, aligning with the explanatory research category as defined by Neuman (2014). The research attempted to provide justification for the interplay between Visionary Leadership, Team Boundary Management, Team Cohesion, Team Knowledge Collaboration and Team Innovation. In addition to this, the study made use of primary data collection and sought to empirically test the

conceptual relationships and assess the influence of leadership on team dynamics and creativity.

2.2. Population and Sampling

The study was conducted on nine companies of palm oil factories in Rokan Hulu Regency, Riau, Indonesia. Rokan Hulu Regency stood out as it is one of the country's largest palm oil producers and would provide valuable empirical context for researching leadership and innovation in an important industrial setting within Indonesia. A total of 725 innovation staff employees working for the companies was set as a population in this research. This subpopulation was deemed fit as it directly plays a role in innovation activities, making this segment relevant to the research objectives of leadership and innovation within the palm oil industry.

The data in this research were analyzed using structural equation modeling (SEM), and the sample size is in accordance with (Civelek, 2018) recommendations that suggested at least 200, ideally between 200–500 participants for SEM. This sample of 280 respondents satisfies these conditions and is more than ten times the number, making analysis valid for this work.

2.3. Operationalization Concept

The study operationalized key concepts, including Visionary Leadership, Team Boundary Management, Team Cohesion, Team Knowledge Collaboration, and Team Innovation were operationalized through specific indicators measured via the questionnaire. The operationalization process focused on translating abstract theoretical concepts into measurable constructs. Each variable was defined based on the literature review and measured through a series of questions designed to assess the respondents' perceptions and experiences in relation to these constructs within the context of their work environment.

2.4. Instrument

This research used a structured questionnaire as the main data collection instrument to assess variables, such as visionary leadership, team cohesion; team knowledge exchange and boundary management for teams. The instrument was pilot tested on 30 initial respondents to evaluate its appropriateness for this particular setting, clarity and effectiveness. The second iteration was created based on feedback to ensure that the questions could measure accurately what they aimed for. The reformed questionnaire showed an acceptable reliability value equal to the threshold of 0.70 in all variables.

This research maintained the validity of results by establishing and using measurement scales that was used in the previous research. In the measuring visionary leadership, a scale based on Jensen et al., (2019) which measured inspirational motivation attributes to vision articulation and team goal alignment by communication was used. Team cohesion was evaluated using Festinger (1950) cohesion scale measured bonding and members of a team. The scale for team knowledge collaboration was adapted from Voet & Steijn (2021), focusing on how good of the elements members exchange information and communicate each other. In the last scale, team boundary management items were adopted from Kossek & Lautsch (2012), These assess how well teams handle interactions with those outside of the group.

2.5. Procedure Data Collection

Data collection involved the distribution of the validated questionnaire to 280 respondents across the nine palm oil factory companies. The questionnaire captured responses on various aspects of leadership and team innovation, using a Likert scale to quantify perceptions and experiences.

2.6. Data Analysis

All of the data were conducted during interview and processed to descriptive statistics, as well further analysis using structural equation modeling (SEM) for testing some hypotheses. The significance testing is performed using the P-value and a proportion of variance explained by the model, called R-Square value (R^2). This was conducted to provide a more complete picture of the consequences of leadership on team innovation.

This research used Partial Least Squares SEM (PLS-SEM) approach due to the exploratory nature of our study and were predicting relationship among visionary leadership, team dynamics and innovation. PLS-SEM is particularly suitable for theory development and smaller sample sizes, such as the 280 respondents used in this study. Unlike Covariance-Based SEM (CB-SEM), which focuses on model fit and requires larger samples, PLS-SEM is ideal for analyzing complex models where prediction and understanding of variable relationships are key objectives.

3. RESULTS

3.1. Validity Testing

Table 1: The Results of Validity Indicator Testing in Full Model.

Code	Indicator	Factor Loading	Remarks
Visionary Leadership			

VL1	Company leaders have a clear vision for the company's sustainability	0.760	Valid
VL2	Company leaders strive to ensure that the team works in accordance with the company's vision	0.813	Valid
VL3	Our leaders always explain the contributions that employees can make	0.925	Valid
VL4	Company leaders always raise employee enthusiasm	0.765	Valid
VL5	Company leaders are optimistic about the company's position in the future	0.754	Valid
Team cohesion			
TC1	In a team environment. each member supports each other to reach the performance goals of team.	0.925	Valid
TC2	In a team environment. each member takes responsibility for both progress and downturns	0.943	Valid
TC3	In a team environment. each member helps each other complete tasks	0.886	Valid
TC4	The team always maintains a sense of harmony together	0.721	Valid
TC5	The team has the trust of fellow team members	0.511	Valid
Team Boundary Management			
TBM1	Team members are willing to receive input from stakeholders related to the company	0.590	Valid
TBM2	Team members actively seek information from stakeholders regarding the company	0.800	Valid
TBM3	Team members proactively ask stakeholders related to the company	0.957	Valid
TBM4	Team members are able to convince stakeholders if needed	0.788	Valid
TBM5	Team members are able to maintain relationships with stakeholders relevant to the company	0.541	Valid
Team knowledge collaboration			
TKC1	My team members are always ready to find and share new useful information	0.738	Valid
TKC2	My team ensures all tasks are completed on time and to a high standard of quality.	0.744	Valid
TKC3	My team is well coordinated with other teams in the organization.	0.771	Valid
TKC4	My team members often propose creative and innovative ideas during meetings.	0.885	Valid
TKC5	My team members are able to evaluate ideas and plans critically and objectively.	0.866	Valid
TKC6	My team members have special skills that are beneficial to the team project.	0.933	Valid
TKC7	My team members encourage the team to stay focused and motivated in achieving goals.	0.902	Valid
TKC8	My Team Members are efficient in implementing plans into real action.	0.852	Valid
TKC9	My team members work well together and support each other.	0.652	Valid
Team Innovation			
TI1	Team members are capable of implementing new ideas that support the improvement of the company's product and service quality.	0.636	Valid
TI2	The company supports the team in carrying out innovations.	0.766	Valid
TI3	Team members are able to create new services. methods. or procedures that reflect innovation.	0.927	Valid
TI4	The company takes into consideration methods and procedures to enhance performance.	0.790	Valid

Table 1 indicates that all indicators for the latent variables studied have factor loadings higher than 0.5. Therefore, it is able to be stated that these indicators are claimed to be valid for use in structural equation modelling (SEM) testing.

The descriptive analysis of the 280 respondents, drawn from innovation staff at nine palm oil factories in Rokan Hulu Regency, provides valuable insights into their demographics. Most respondents were in the 31-35 age range, accounting for 36.8% of the sample, indicating that the workforce is largely composed of individuals in their prime working years. The least represented age groups were those aged 46 and older, with only 1.4% in each of these categories. This suggests a younger, more dynamic workforce focused on innovative tasks within the industry.

The gender distribution was overwhelmingly male, with 97.1% of respondents identifying as male. This is consistent with the broader demographic trends in the palm oil industry, which tends to have a predominantly male workforce. Educationally, the majority of respondents (73.9%) held a bachelor's degree or higher, indicating that the staff involved in innovation roles are highly educated and possess the necessary qualifications to contribute to leadership, team cohesion, and knowledge collaboration.

In terms of work experience, 56.1% of respondents had 1-5 years of experience, suggesting that the majority are relatively new but experienced enough to understand company operations and challenges. Only a small percentage (3.2%) had over 20 years of experience, indicating a limited presence of long-serving employees in innovation roles. This balance between education and experience positions the workforce well for innovation and adaptation in the industry.

Overall, the demographic data points to a skilled and relatively young workforce engaged in the innovation process. While there is room for improvement in gender balance, the high levels of education and moderate work experience suggest that the innovation staff are well-equipped to tackle industry challenges and drive forward innovative initiatives in their respective companies.

3.2. Reliability Testing

Table 2: The Results of Reliability Testing.

Indikator	λ	λ^2	$1 - \lambda^2$	CR	AVE
Visionary Leadership					
VL1	0.760	0.578	0.422	0.902	0.650
VL2	0.813	0.661	0.339		
VL3	0.925	0.856	0.144		
VL4	0.765	0.585	0.415		
VL5	0.754	0.569	0.431		
Σ	4.017	3.248	1.752		
Team cohesion					
TC1	0.925	0.856	0.144	0.904	0.662
TC2	0.943	0.889	0.111		
TC3	0.886	0.785	0.215		
TC4	0.721	0.520	0.480		
TC5	0.511	0.261	0.739		
Σ	3.986	3.311	1.689		
Team Boundary Management					
TBM1	0.590	0.348	0.652	0.861	0.564
TBM2	0.800	0.640	0.360		
TBM3	0.957	0.916	0.084		
TBM4	0.788	0.621	0.379		
TBM5	0.541	0.293	0.707		
Σ	3.676	2.818	2.182		
Team knowledge collaboration					
TKC1	0.738	0.545	0.455	0.948	0.673
TKC2	0.744	0.554	0.446		
TKC3	0.771	0.594	0.406		
TKC4	0.885	0.783	0.217		
TKC5	0.866	0.750	0.250		
TKC6	0.933	0.870	0.130		
TKC7	0.902	0.814	0.186		
TKC8	0.852	0.726	0.274		
TKC9	0.652	0.425	0.575		
Σ	7.343	6.061	2.939		
Team Inovation					
TI1	0.636	0.404	0.596	0.864	0.618
TI2	0.766	0.587	0.413		
TI3	0.927	0.859	0.141		
TI4	0.789	0.623	0.377		
Σ	3.118	2.473	1.527		

Table 2 indicates that the entire variables get a construct reliability (CR) value greater than 0.7. with the lowest CR value being 0.861 for the Team Boundary Management variable. Additionally, all variables obtained values of AVE which are greater than 0.5. with the lowest AVE value being 0.564 for the Team Boundary Management variable. Given that values of CR are higher than 0.7 and AVE higher than 0.5. it can be concluded that all instruments are reliable.

3.3. SEM Model Analysis Results

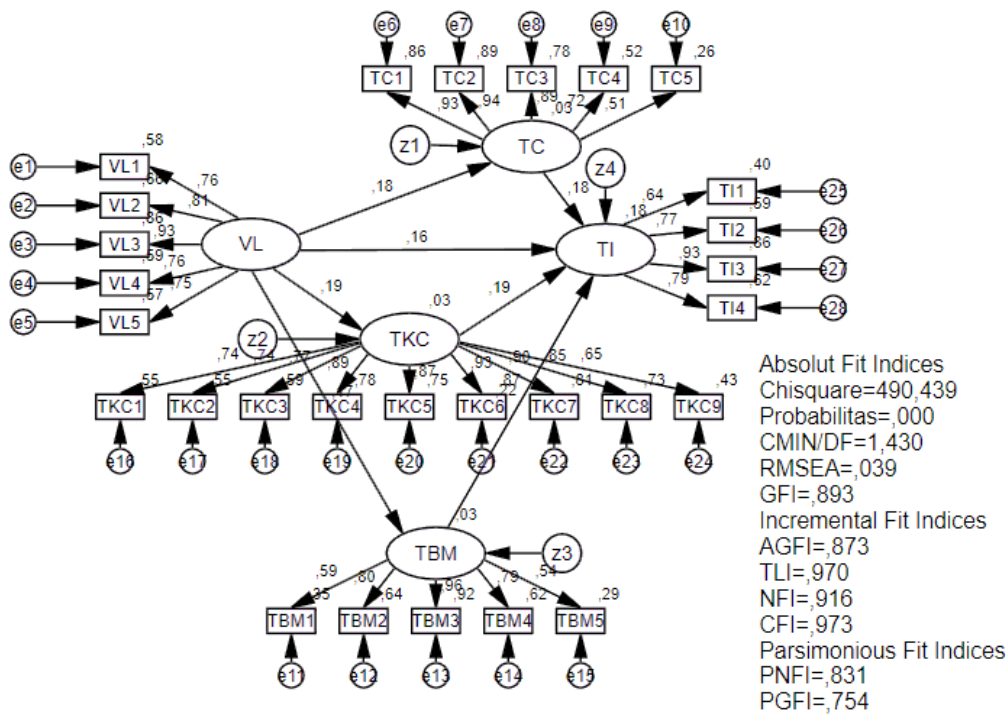

Figure 1: SEM Model Analysis Results.

Table 3: GoF full structural model test results.

Indikator Goodness-of-fit	Recommendation Value	Model Results	Information
Absolut Fit Indices			
Chi-Square (df=342, p=0,05)	< 386,125	490,439	Not Fit
Sig. probability	≥ 0,05	0,000	Not Fit
CMIN/DF	≤ 2,00	1,430	Fit
RMSEA	≤ 0,08	0,039	Fit
GFI	≥ 0,90	0,893	Moderate
Incremental Fit Indices			
AGFI	≥ 0,90	0,873	Moderat
TLI	≥ 0,90	0,970	Fit
NFI	≥ 0,90	0,916	Fit
CFI	≥ 0,90	0,973	Fit
Parsimonious Fit Indices			
PNFI	0,6 – 0,9	0,831	Fit
PGFI	0 – 1	0,754	Fit

Table 2 shows that not all GoF indicators meet the fit criteria. However, in each goodness of fit criterion there are fit indicators, so the endogenous construct CFA model is considered fit.

3.4. SEM Assumption Test

In Structural Equation Modelling (SEM) analysis, several assumptions must be met to ensure valid and reliable results. In this research, sample tests, normality tests, and outlier tests will be conducted. However, multicollinearity testing will not be performed. According to Tjahjono et al. (2021), multicollinearity testing is unnecessary if the SEM model includes only one exogenous variable.

3.5. Sample Tests

In structural equation modelling, many fit indices are influenced by sample size. Some sources recommend a minimum size of sample of 150 for structural equation models, while others suggest that this size of sample can become at least 10 times the number of parameters assumed in the model. According to Civelek (2018) a sample size of at least 200. and preferably between 200 and 500. is recommended. Given that this study has a sample size of 280. it meets these recommendations, as it falls within the range of 200-500 and exceeds the requirement of being 10 times the number of estimated parameters.

3.6. Normality Test

In structural equation modelling, Maximum Likelihood Estimation (MLE) assumes that the data follows a

normal distribution, both univariate and multivariate (Tjahjono et al., 2021). Result of Normality Test presented in Table 4. More detailed information regarding the respondents' demographic data can be found in Appendix. Data shows that all critical ratio (c.r) values for skewness fall within the range of ± 2.58 , indicating that all univariate indicators have a normal distribution. Additionally, the c.r. value for Mardia's multivariate kurtosis is -1.212, which is within the expected range of -2.58 to +2.58. Therefore, it is able to be shown that the research model also exhibits a normal distribution in multivariate terms (Ghozali, 2017).

Table 4: Normality test results.

Variable	Min.	Max.	Skew	C.R.	Kurtosis	C.R.
TKC1	1.000	7.000	-0.323	-2.203	-0.921	-3.145
TKC2	1.000	7.000	-0.186	-1.274	-0.526	-1.795
TKC3	1.000	7.000	-0.326	-2.226	-0.488	-1.665
TKC4	1.000	7.000	0.101	0.690	-1.037	-3.542
TKC5	1.000	7.000	-0.071	-0.485	-0.854	-2.915
TKC6	1.000	7.000	0.245	1.673	-1.158	-3.955
TKC7	1.000	7.000	0.213	1.453	-1.061	-3.626
TKC8	1.000	7.000	0.056	0.382	-0.976	-3.335
TKC9	1.000	7.000	-0.229	-1.565	-0.564	-1.925
TBM1	1.000	7.000	-0.351	-2.395	-0.238	-2.813
TBM2	2.000	7.000	0.026	0.180	-0.674	-2.302
TBM3	2.000	7.000	0.090	0.618	-1.137	-3.882
TBM4	2.000	7.000	-0.221	-1.511	-0.836	-2.855
TBM5	2.000	7.000	-0.056	-0.379	-0.736	-2.514
TI4	1.000	7.000	-0.291	-1.991	-0.624	-2.131
TI3	2.000	7.000	0.166	1.137	-1.093	-3.732
TI2	3.000	7.000	-0.029	-0.199	-1.093	-3.734
TI1	3.000	7.000	-0.348	-2.380	-0.635	-2.167
VL1	1.000	7.000	-0.129	-0.879	-0.707	-2.416
VL2	1.000	7.000	0.047	0.323	-0.637	-2.176
VL3	2.000	7.000	0.062	0.422	-0.716	-2.447
VL4	2.000	7.000	-0.352	-2.405	-0.651	-2.223
VL5	2.000	7.000	-0.151	-1.034	-0.975	-3.332
TC5	3.000	7.000	-0.010	-0.069	-0.983	-3.359
TC4	2.000	7.000	-0.142	-0.967	-0.913	-3.117
TC3	3.000	7.000	0.095	0.649	-1.010	-3.449
TC2	2.000	7.000	0.270	1.845	-0.969	-3.309
TC1	1.000	7.000	-0.216	-1.477	-0.713	-2.434
Multivariate					-5.936	-1.212

3.7. Hypothesis Testing

In this study, direct influence hypothesis testing (H_1 to H_7) in SEM was conducted using regression weights. The testing employed the critical ratio (c.r.) value, with a p-value ≤ 0.05 indicating the rejection of H_0 , and a p-value > 0.05 leading to the acceptance of H_0 . A three-star p-value (***) denotes a very low value, specifically < 0.001 , and is reported as 0.000. The results of the regression weights are summarized in Table 5.

Table 5: Regression Weights.

			Estimate	S.E.	C.R.	P	Remarks
TI	<---	VL	0.120	0.049	2.433	0.015	Significant
TC	<---	VL	0.292	0.104	2.808	0.005	Significant
TBM	<---	VL	0.115	0.046	2.504	0.012	Significant
TI	<---	TC	0.084	0.029	2.894	0.004	Significant
TI	<---	TBM	0.240	0.072	3.326	0.000	Significant
TKC	<---	VL	0.174	0.060	2.884	0.004	Significant
TI	<---	TKC	0.159	0.052	3.078	0.002	Significant

Remarks:

VL : Visionary Leadership

TC : Team cohesion

TBM : Team Boundary Management

TI : Team innovation

TKC : Team knowledge collaboration

Then the data were tested using the Sobel test via Winnifred's Mediation Program (WIMP). If a p-value ≤ 0.05 is obtained, H_0 is rejected; if the p-value is > 0.05 , H_0 is accepted.

The Results of the Sobel Test on the Influence of Visionary Leadership on Team Innovation with as

Team Cohesion the Mediating Variable are shown in the Table 6

Table 6. The results of the sobel test.

Unstandardized coefficient of IV -> Mediator (a):	0.292	
Standard error of IV -> Mediator (se a):	0.104	
Unstandardized coefficient of M->DV with IV in eqn (b):	0.084	
Standard error of M->DV with IV in eqn (se b):	0.029	Two-tailed p value
Sobel's z	2.0160	0.0438
Aroian's z	1.9568	0.0504
Goodman's z	2.0810	0.0374

The Results of the Sobel Test on the Influence of Visionary Leadership on Team Innovation with as Team Knowledge Collaboration the Mediating Variable are shown in the Table 7.

Table 7: Results of the Sobel Test.

Unstandardized coefficient of IV -> Mediator (a):	0.174	
Standard error of IV -> Mediator (se a):	0.060	
Unstandardized coefficient of M->DV with IV in eqn (b):	0.159	
Standard error of M->DV with IV in eqn (se b):	0.052	Two-tailed p value
Sobel's z	2.1041	0.0354
Aroian's z	2.0473	0.0406
Goodman's z	2.1660	0.0303

The outcomes of the Sobel test examining the effect of Visionary Leadership on Team Innovation, with Team Boundary Management as a mediating variable, are described in the Table 8.

Table 8: The results of the Sobel test.

Unstandardized coefficient of IV -> Mediator (a):	0.115	
Standard error of IV -> Mediator (se a):	0.046	
Unstandardized coefficient of M->DV with IV in eqn (b):	0.240	
Standard error of M->DV with IV in eqn (se b):	0.072	Two-tailed p value
Sobel's z	2.0000	0.0445
Aroian's z	1.9448	0.0518
Goodman's z	2.0602	0.0394

The hypothesis testing results indicate that all hypotheses are accepted with positive C.R. values and $p < 0.05$ as follows.

1. Visionary Leadership positively affects Team Innovation (H1).
2. Visionary Leadership positively affects Team Cohesion (H2).
3. Visionary Leadership positively affects Team Boundary Management (H3).
4. Team cohesion positively affects Team Innovation (H4).
5. Team Boundary Management positively affects Team Innovation (H5).
6. Visionary Leadership positively affects team knowledge collaboration (H6).
7. Team knowledge collaboration positively affects Team Innovation (H7).
8. Team cohesion mediates the positive influence of Visionary Leadership on Team Innovation (H8).
9. Team knowledge collaboration mediates the positive influence of Visionary Leadership on Team Innovation (H9).
10. Team Boundary Management mediates the positive influence of Visionary Leadership on Team Innovation (H10).

4. DISCUSSION

4.1. The Influence of Visionary Leadership on Team Innovation

The research outcomes indicate that Visionary Leadership positively influences Team Innovation, suggesting that improved Visionary Leadership enhances Team Innovation (van der Voet & Steijn, 2021). Visionary Leadership provides essential resources, support, and a conducive environment for employees to develop and implement new ideas within a competitive and dynamic business context. Visionary leaders inspire their teams with a clear vision, foster collaboration, and cultivate an environment that supports the exploration of innovative ideas. Research demonstrates that Visionary Leadership is associated positively with increased innovation of team, as a clear vision aligns team members and motivates them to innovate (van der Voet & Steijn, 2021). The result is supported by (Utomo et al., 2022), which shows that Visionary Leadership is closely related to enhanced employee performance and organizational success.

However, in the context of the palm oil industry, the relevance of this relationship becomes more pronounced due to the pressing need for innovation driven by environmental regulations and sustainability demands. Visionary leaders in this industry are crucial for guiding teams toward innovative solutions that balance

productivity and environmental responsibility. In fact, these leaders will likely encourage hands-on testing and ongoing problem-solving that are essential to the iterative innovation of more sustainable processes or products. In a context when the operations and ecological responsibility both matters, visionary leadership is thus all the more important in prompting teams to come up with innovative solutions which benefits operating efficiency. Leaders with a clear vision can inspire their teams to explore new technologies or practices that improve both productivity and environmental sustainability.

4.2. The Influence of Visionary Leadership on Team Cohesion

Based on the research result, the higher Visionary Leadership will increase the team cohesion (van der Voet & Steijn, 2021). In addition, strong team cohesion contributes to innovation by creating an experimental, idea-sharing and collaborative environment. An inspiring, compelling vision; unifying the common purpose of everyone in its gaze and focuses on fostering relationships between team members is how Visionary Leadership can improve the whole of sense team cohesion. This is consistent with the theorization about how visionary leadership fosters team cooperation and accountability through the positive recognition of each member's contribution (van der Voet & Steijn, 2021).

In the palm oil industry where businesses may be logistically disparate and teams are often working in remote locations, strong team cohesion is critical to maintaining collaborative relationships with confidence. Moreover, in places when the conversation among workmates are difficult, such visionaries improve connectedness between team members with a collective comprehension that streamlines teamwork and an effective implementation of groundbreaking solutions. One of the keys with Visionary Leadership to build strong teams, especially in a geographically dispersed environment (applies also for most palm oil sector), is clear leadership towards collaboration and alignment on key goals that support head office envision.

4.3. The Influence of Visionary Leadership on Team Boundary Management

The results show a positive influence of Visionary Leadership on the Team Boundary Management, which implies that with more Visionary Leadership provided better can be done in practice over managing team boundaries. It focusses on direction by creating strategic vision and mission a proper limit for maximum engagement with an emphasis upon functional norms. Moreover, visionary leaders communicate an inspiring vision that frames all the elements of performance and guides each team member in understanding their role collectively, which makes it easy to collaborate and communication across various segments of teams. A well-defined vision is helpful in enabling the team to accept inputs from stakeholders and will help search for desired information that helps Team Boundary Management, which translates into organizational sustainability (Eseryel et al., 2021).

Managing relationships with suppliers, technology partners, and environmental agencies is essential in the palm oil sector. Teams may negotiate these external relationships with the assistance of visionary leaders who successfully convey the organization's mission, guaranteeing access to the tools, information, and technologies that stimulate the team's creativity. In addition, effective boundary management is vital for the palm oil business because of its reliance on outside resources, including regulatory compliance and technical improvements. Based on the research result, it can be said that visionary leaders play a key role in ensuring that teams collaborate across boundaries, leveraging external partnerships to foster innovation.

4.4. The Influence of Team Cohesion on Team Innovation

The results show that team cohesion positively affects team invention, suggesting that more cohesive teams are more innovative. This important and favorable relationship implies that a strong sense of team connection to improves their creativity. Moreover, effective teamwork requires team cohesion because it encourages cooperation, knowledge exchange, and a decrease in conflict. In addition, secure and encouraging atmosphere that promotes experimentation, risk-taking, and idea sharing is created by cohesive teams. Additionally, this cohesiveness fosters dedication to common objectives, increases trust, and fosters creativity—all of which lead to creative solutions. Cohesive teams are better equipped to apply fresh concepts that raise the caliber of goods and services by resolving disputes amicably and directing disagreements toward creative solutions (Özer & Karabulut, 2019).

In the palm oil sector, where teams frequently work in difficult environments with limited resources and remote places, good team cohesion helps teams to overcome these obstacles by working together. Teams that work collaboratively are better able to investigate new ideas and make adjustments that increase sustainability and productivity. Since palm oil businesses are distributed, team cohesion is essential to promoting innovation. In addition, teams that maintain strong connection even when they are geographically separated are better at exchanging ideas and working together to develop creative solutions.

4.5. The Influence of Team Boundary Management on Team innovation

Based on the research results, it shows that team boundary management has a positive impact on team innovation, implying that better team boundary management promotes more team innovation. This positive and

significant relationship shows that effective management of team boundaries has a beneficial impact on innovation.

Innovation necessitates proficient management both within the company and in interactions with external parties. Team Boundary Management, which oversees relationships and interactions with external stakeholders, is positively related to employee creativity and also team innovation. Effective management of team boundaries facilitates access to external resources such as information, knowledge, technology, and talent, all of which support innovation. Engaging with external parties enriches idea generation and problem-solving, enhances collaboration, and helps teams adapt to industry changes. Proactive communication with stakeholders allows teams to better understand challenges and opportunities, develop innovative approaches, and secure external support for implementing innovations, ultimately improving the quality of company products and services (van der Voet & Steijn, 2021)

In the palm oil sector, where external collaborations are critical for accessing new technologies and complying with regulations, effective boundary management is essential for driving innovation. Teams that manage these relationships well are more likely to generate innovative solutions.

4.6. The Influence of Visionary Leadership on Team Knowledge Collaboration

The outcomes indicate a positive influence of Visionary Leadership on team knowledge collaboration, suggesting that stronger Visionary Leadership enhances team knowledge collaboration. This significant relationship demonstrates that effective Visionary Leadership can significantly improve team knowledge collaboration. Visionary leadership is crucial in fostering team knowledge collaboration by creating an environment conducive to innovation, continuous learning, overcoming challenges, increasing commitment and motivation, and building networks and relationships (Torres, 2019). Visionary leaders assist team members grasp common objectives and the value of knowledge collaboration by articulating a compelling vision. They support team members' critical thinking, exploration of innovative concepts, and sharing of resources, ideas, and information. In addition, mutual trust and open and honest communication develop a safe environment where workmates may share their knowledge and have discussions without worrying about being judged (Thahira et al., 2020).

In addition, visionary leaders also set high standards for team accomplishments and work quality, inspiring and motivating their teams to collaborate toward mutual goals. Effective collaboration fosters competitive advantages for businesses by transforming knowledge into a strategic resource (Rehman & Iqbal, 2020). Moreover, leaders in the palm oil sector who articulate an inspiring goal can create an atmosphere that encourages information sharing and productive teamwork. The innovation depends on this culture of knowledge sharing since it allows teams to come up with innovative solutions to industry problems by combining a variety of perspectives. In the palm oil sector, visionary leadership promotes knowledge collaboration by fostering an environment of transparency and trust where team members are inspired to contribute their thoughts and perspectives. This collaborative approach is essential for developing innovative practices that enhance productivity and sustainability.

4.7. The Influence of Team Knowledge Collaboration on Team Innovation

Based on the research result, it indicates a positive relationship between team knowledge collaboration and team innovation, means that effective collaboration enhances the team's ability to innovate (Zhang et al., 2023). In team knowledge cooperation, members use their diverse backgrounds and specialties to solve challenges in innovative ways and encourage one another to come up with fresh concepts. Knowledge sharing, reciprocal learning, and invention are all facilitated by this cooperative endeavor. In addition, having access to common knowledge accelerates innovation development cycles and produces solutions of higher quality. Moreover, teams that are willing to engage while maintaining lines of communication open can more readily share ideas, which results in more thorough and imaginative inventions. Furthermore, corporate sponsorship for innovation teams encourages team members to investigate novel concepts, resulting in improvements that improve the caliber of goods or services. (Zhang et al., 2023).

Since operations in the palm oil sector are complex and require teams to integrate a variety of knowledge fields, including supply chain management, environmental science, and agronomy, knowledge cooperation is especially crucial. In teams, open communication and knowledge exchange speed up invention cycles and make it possible to create efficient and sustainable manufacturing methods. In addition, the innovation in the palm oil industry depends on the integration of varied expertise through knowledge sharing. Teams that effectively share knowledge are better positioned to develop innovative solutions that address both productivity and sustainability challenges.

4.8. Team Cohesion in Mediating the Influence of Visionary Leadership on Team innovation

The findings indicate that team cohesion mediates the relationship between Visionary Leadership and team innovation, suggesting that leaders enhance innovation indirectly by fostering team cohesion (Voet & Steijn 2021). Research by Voet & Steijn (2021) supports the team cohesion's mediating role in the influence of Visionary

Leadership and also team innovation. Visionary leaders create a shared understanding of the members, which supports innovation in services and processes. According to (West & Anderson, 1996), team innovation is more significantly influenced by social and interpersonal processes than by structural characteristics or resources. Additionally, research by (Özer & Karabulut, 2019; Shi et al., 2021) demonstrates how team cohesion has a big impact on team creativity. Strong team cohesion promotes cooperation toward creative goals and guarantees alignment with the vision and goals established by visionary leadership. Additionally, it helps teams overcome obstacles as a group, promotes the realization of creative visions, and builds trust between leaders and members.

Cohesive teams in the palm oil sector are better able to support the vision established by visionary leaders, which facilitates more productive collaboration and the creation of creative answers to challenging problems. Cohesive teams are crucial to converting visionary leadership into creative results in the palm oil sector. Cohesive teams can accomplish the creative objectives set by their leaders by cultivating trust and cooperation.

4.9. Team Knowledge Collaboration in Mediating the Influence of Visionary Leadership on Team Innovation

According to the research, the relationship between team creativity and visionary leadership is mediated by team knowledge cooperation. Visionary leaders that cultivate a culture of collaborative knowledge sharing allow their teams to develop more successfully in the palm oil business, where complex problems necessitate interdisciplinary solutions (Alobeidli et al., 2024). Visionary leadership facilitates the sharing and integration of multiple perspectives, increases team knowledge collaboration, and directs the team towards long-term objectives by presenting a compelling and clear vision. Teams are able to encourage creativity and produce original solutions to problems through transparent communication and knowledge sharing. This approach increases team innovation by implementing new ideas that improve the company's procedures, services, and product quality.

In the palm oil industry, knowledge collaboration is key to innovation, as teams must integrate expertise from various fields. Visionary leaders who encourage knowledge-sharing enhance their team's ability to innovate and develop sustainable solutions.

4.10. Team Boundary Management in Mediating the Influence of Visionary Leadership on Team Innovation

The results show that Team Boundary Management mediates the influence of Visionary Leadership on team innovation. Visionary leaders who encourage teams to manage external relationships effectively can enhance innovation by providing access to external resources and expertise (Yan et al 2019). Eseryel et al (2021) show how establishing a clear vision and defining organizational boundaries are two ways that visionary leadership affects team boundary management. In order to increase access to information, technology, and other external resources that promote innovation, visionary leaders inspire teams to manage relationships with external organizations, such as suppliers, experts, or strategic partners. Additionally, by encouraging teams to explore possibilities for new perspectives and concepts from outside the company, this leadership style fosters critical thinking and the adoption of creative ideas to improve the company's goods and services.

This mediation is especially important in the palm oil sector, because innovation frequently relies on external collaborations. In the palm oil industry, managing external connections is essential to gaining access to the information and resources required for innovation. In order to help teams cross these boundaries and foster creativity, visionary leaders are essential.

5. CONCLUSIONS

According to the data analysis and also test of hypothesis by method of SEM, this study concludes that visionary leadership exerts both direct and also indirect influences on team innovation. Visionary leaders not only directly encourage innovation but also indirectly through enhancing team cohesion and also fostering effective boundary management and knowledge collaboration of team. Clear boundaries set by visionary leaders ensure effective team operation within established parameters, further enhancing innovation capabilities. The outcomes also underscore the significant role of visionary leadership to help opening up for team innovation, cohesion, and boundary management. Effective visionary leadership creates an environment where teams are cohesive, manage boundaries well, and collaborate effectively in knowledge sharing, all contributing to enhanced innovation.

5.1. Limitations and Implications

In this study, the researchers focused exclusively on palm oil industry workers in Rokan Hulu Regency, specifically targeting innovation staff within companies. Consequently, potential insights from respondents in other sectors, such as banking, which could provide different perspectives on team cohesion within organizations, were not included in the investigation. Additionally, the research employed a cross-sectional approach and distributed questionnaires, limiting the depth and longitudinal insights that could be gained into the research phenomena.

The research findings underscore the importance of visionary leadership in enhancing team cohesion and also subsequently, team innovation. Management efforts should prioritize the development of visionary leadership

skills among team leaders. Moreover, while team cohesion may not have a direct effect on driving team innovation, it plays an essential role in creating a supportive organizational environment that encourages collaboration and fosters the conditions necessary for innovation to thrive. Additionally, efforts to improve team innovation should focus on enhancing team boundary management and promoting effective knowledge collaboration within teams. These actions are pivotal in nurturing a culture of innovation within organizations.

Once the hypotheses are tested and proven, the priority should be placed on factors that most significantly drive team innovation.

Visionary Leadership and Team Boundary Management (10) should follow closely in priority. Proven effectiveness of this hypothesis indicates that organizations must enable leaders to manage team boundaries well, fostering external interactions that bring in diverse perspectives. This will allow teams to innovate by accessing broader resources and shielding teams from distractions.

Visionary Leadership and Team Knowledge Collaboration (9) should be a top priority if proven, as knowledge collaboration is vital for fostering innovation. Visionary leaders enable teams to share, integrate, and apply knowledge effectively, which enhances creativity and problem-solving capabilities. If confirmed, this hypothesis could suggest that organizations must focus on improving leadership that promotes an open, collaborative culture.

Visionary Leadership and Team Cohesion (H8), while important, may take a secondary priority if the link between cohesion and innovation is weaker than boundary management and knowledge collaboration. However, cohesion remains critical for building trust and communication, which indirectly supports a healthy environment for innovation.

Thus, leadership efforts should first focus on enhancing knowledge collaboration and boundary management, as they directly contribute to innovation. Team cohesion remains essential for sustaining long-term team performance and organizational health, albeit with a less immediate impact on innovation.

REFERENCES

- Alobeidli, S. Y., Ahmad, S. Z., & Jabeen, F. (2024). Mediating effects of knowledge sharing and employee creativity on the relationship between visionary leadership and innovative work behavior. *Management Research Review*, 47(6), 883–903. <https://doi.org/10.1108/MRR-02-2023-0144>
- Aslam, M. (2020). Leadership in challenging times of academic libraries. *Global Knowledge, Memory and Communication*, 69(3), 135–149. <https://doi.org/10.1108/GKMC-03-2019-0038>
- Bunnoiko, K., & Atthirawong, W. (2017). Confirmatory factor analysis towards visionary leadership of supply chain managers in the manufacturing industry of Thailand. *Journal for Global Business Advancement*, 10(4), 395–414. <https://doi.org/10.1504/JGBA.2017.086518>
- Cinnioğlu, H. (2020). A Review of Modern Leadership Styles in Perspective of Industry 4.0. *Agile Business Leadership Methods for Industry 4.0*, 1–23. <https://doi.org/10.1108/978-1-80043-380-920201002>
- Civelek, M. E. (2018). *Essentials of Structural Equation Modelling*. Zea Books.
- Escher, I., & Brzustewicz, P. (2020). Inter-organizational collaboration on projects supporting sustainable development goals: The company perspective. *Sustainability (Switzerland)*, 12(12). <https://doi.org/10.3390/su12124969>
- Eseryel, U. Y., Crowston, K., & Heckman, R. (2021). Functional and Visionary Leadership in Self-Managing Virtual Teams. *Group and Organization Management*, 46(2), 424–460. <https://doi.org/10.1177/1059601120955034>
- Festinger, L. (1950). Informal Social Communication. *Psychological Review*, 57(5), 271–282. <https://doi.org/https://doi.org/10.1037/h0056932>
- Ghozali, I. (2017). *Analisis Multivariat dan Ekonometrika : Teori, Konsep dan Aplikasi dengan EVIEWS 10*.
- Grass, A., Backmann, J., & Hoegl, M. (2020). From Empowerment Dynamics to Team Adaptability: Exploring and Conceptualizing the Continuous Agile Team Innovation Process. *Journal of Product Innovation Management*, 37(4), 324–351. <https://doi.org/10.1111/JPIM.12525>
- Hall, K. L., Vogel, A. L., & Crowston, K. (2019). Comprehensive Collaboration Plans: Practical Considerations Spanning Across Individual Collaborators to Institutional Supports. *Strategies for Team Science Success: Handbook of Evidence-Based Principles for Cross-Disciplinary Science and Practical Lessons Learned from Health Researchers*, 587–612. https://doi.org/10.1007/978-3-030-20992-6_45
- Hughes, D. J., Lee, A., Tian, A. W., Newman, A., & Legood, A. (2018). Leadership, Creativity, and Innovation: A Critical Review and Practical Recommendations. *Leadership Quarterly*, 29(5), 549–569. <https://doi.org/https://doi.org/10.1016/j.leaqua.2018.03.001>
- Jensen, U. T., Andersen, L. B., Bro, L. L., Bøllingtoft, A., Eriksen, T. L. M., Holten, A.-L., Jacobsen, C. B., Ladenburg, J., Nielsen, P. A., Salomonsen, H. H., Westergård-Nielsen, N., & Würtz, A. (2019). Conceptualizing and Measuring Transformational and Transactional Leadership. *Administration & Society*, 51(1), 3–33. <https://doi.org/10.1177/0095399716667157>
- Kao, C. (2019). Development of team cohesion and sustained collaboration skills with the sport education model. *Sustainability (Switzerland)*, 11(8). <https://doi.org/10.3390/su11082348>
- Kearney, E., Shemla, M., van Knippenberg, D., & Scholz, F. A. (2019). A paradox perspective on the interactive effects of visionary and empowering leadership. *Organizational Behavior and Human Decision Processes*, 155(December 2018), 20–30. <https://doi.org/10.1016/j.obhdp.2019.01.001>
- Kim, S. L., Lee, D., & Yun, S. (2022). Leader boundary-spanning behavior and creative behavior: the role of need for status and creative self-efficacy. *Leadership and Organization Development Journal*, 43(6), 835–846. <https://doi.org/10.1108/LODJ-05-2021-0235>
- Knippenberg, D. van, & Stam, D. (2014). Oxford Handbooks Online. In *Choice Reviews Online*, 50(11). <https://doi.org/https://doi.org/10.5860/choice.50-5912>
- Kossek, E. E., & Lautsch, B. A. (2012). Work–family boundary management styles in organizations: A cross-level model. *Organizational Psychology Review*, 2(2), 152–171. <https://doi.org/10.1177/2041386611436264>
- Kou, C. Y. (2021). Team Boundary Spanning in a Large Engineering Project. *Small Group Research*, 52(4), 405–430. <https://doi.org/10.1177/1046496420976836>
- Leinonen, P. (2006). *Facilitating interpersonal evaluation of knowledge in a context of distributed team collaboration*.

<https://doi.org/10.1111/j.1467-8535.2006.00658.x>

- Madi Odeh, R. B. S., Obeidat, B. Y., Jaradat, M. O., Masa'deh, R., & Alshurideh, M. T. (2023). The transformational leadership role in achieving organizational resilience through adaptive cultures: the case of Dubai service sector. *International Journal of Productivity and Performance Management*, 72(2), 440–468. <https://doi.org/10.1108/IJPPM-02-2021-0093>
- Mascareño, J., Rietzschel, E., & Wisse, B. (2020). Envisioning innovation: Does visionary leadership engender team innovative performance through goal alignment? *Creativity and Innovation Management*, 29(1), 33–48.
- Maynard, M. T., Kennedy, D. M., Sommer, S. A., & Passos, A. M. (2015). Team cohesion: A theoretical consideration of its reciprocal relationships within the team adaptation nomological network. *Research on Managing Groups and Teams*, 17, 83–111. <https://doi.org/10.1108/S1534-085620150000017005>
- Neuman, W. L. (2014). Social Research Methods: Qualitative and Quantitative Approaches. In *Teaching Sociology*, 30(3). <https://doi.org/https://doi.org/10.2307/3211488>
- Oh, M., & Choi, S. (2020). The competence of project team members and success factors with open innovation. *Journal of Open Innovation: Technology, Market, and Complexity*, 6(3), 51. <https://doi.org/10.3390/JOITMC6030051>
- Özer, M., & Karabulut, A. T. (2019). The Effects of Team Enablers and Team Cohesion on Project Team Success. *International Journal of Commerce and Finance*, 5(1), 102–120.
- Rehman, U. U., & Iqbal, A. (2020). Nexus of knowledge-oriented leadership, knowledge management, innovation and organizational performance in higher education. *Business Process Management Journal*, 26(6), 1731–1758. <https://doi.org/10.1108/BPMJ-07-2019-0274>
- Richardson, B. M. (2017). An Innovative Transitional Care Program Improves Community Health. In *Journal of Nursing Administration* (Vol. 47, Issues 7–8, pp. 357–358). <https://doi.org/10.1097/NNA.0000000000000493>
- Ronald, B., & Marc, L. (2021). The leadership challenge in times of the COVTD 19 pandemic - An empirical investigation on the impact of transformational leadership on motivation and team performance. *Advances in Management*, 14(3), 1–21.
- Ronald, B., & Marc, L. (2021). The leadership challenge in times of the COVTD 19 pandemic - An empirical investigation on the impact of transformational leadership on motivation and team performance. *Advances in Management*, 14(3), 1–21.
- Saif, M. A. M., Hussin, N., Husin, M. M., Alwadain, A., & Chakraborty, A. (2022). Determinants of the Intention to Adopt Digital-Only Banks in Malaysia: The Extension of Environmental Concern. *Sustainability (Switzerland)*, 14(17), 1–32. <https://doi.org/10.3390/su141711043>
- Shi, K., Zhang, H., & Hu, H. (2021). Does Team cohesion Always Positively Influence Team innovation? A Chain Mediation Model. *Journal*, 8(6), 106–116. *Advances in Social Sciences Research*, 8(6), 106–116. <https://doi.org/https://doi.org/10.14738/assrj.86.10264>
- Tarigan, Z. J. H., Siagian, H., & Jie, F. (2021). Impact of internal integration, supply chain partnership, supply chain agility, and supply chain resilience on sustainable advantage. *Sustainability (Switzerland)*, 13(10). <https://doi.org/10.3390/su13105460>
- Thahira, A., Tjahjono, H. K., & Susanto, S. (2020). The Influence of Transactional Leadership on Organization Innovativeness (OI) Mediated by Organizational Learning Capability (OLC) in Medium Small Enterprise Kendari City. *Jurnal Manajemen Bisnis*, 11(1). <https://doi.org/10.18196/mb.11190>
- Tjahjono, H. K., Basuki, A. T., & Palupi, M. (2021). *Aplikasi SEM dalam Studi Perilaku Organisasional*. UPP STIM YKPN.
- Torres, S. (2019). On Elastic Ties: Distance and Intimacy In Social Relationships. *Sociological Science*, 6, 235–263. <https://doi.org/10.15195/V6.A10>
- Utomo, W. A., Udin, U., & Haryono, S. (2022). Visionary Leadership and Employee Quality in the Public Service Sector. *International Journal of Applied Economics, Finance and Accounting*, 12(2), 31–37. <https://doi.org/10.33094/ijaefa.v12i2.542>
- van der Voet, J., & Steijn, B. (2021). Team innovation through collaboration: how visionary leadership spurs innovation via team cohesion. *Public Management Review*, 23(9), 1275–1294. <https://doi.org/10.1080/14719037.2020.1743344>
- West, M. A., & Anderson, N. R. (1996). Innovation in top management teams. *Journal of Applied Psychology*, 81(6), 680–693. <https://doi.org/10.1037/0021-9010.81.6.680>
- Yan, S., Hu, B., Liu, G., Ru, X., & Wu, Q. (2019). Top management team boundary-spanning behaviour, bricolage, and business model innovation. *Technology Analysis and Strategic Management*, 32(5), 561–573. <https://doi.org/10.1080/09537325.2019.1677885>
- Zhang, Y., Wang, D., & Xiao, X. (2023). Network Characteristics of Innovation Ecosystem: Knowledge Collaboration and Enterprise Innovation. *Science, Technology and Society*, 28(3), 488–510. <https://doi.org/10.1177/09717218231161216>