



Research on Consumer Buying Behavior When Watching Livestreams on Digital Technology Platforms in Vietnam

Nguyen Que Lam¹, Nguyen The Kien^{2*}

¹VNU University of Economics and Business, Vietnam National University, Hanoi. School of Business Administration (PhD candidate), 100000, Vietnam.

²VNU University of Economics and Business, Vietnam National University, Hanoi, 100000, Vietnam; nguyenthekien@gmail.com (N.T.K.).

Abstract. This study provides a comprehensive analysis of consumer purchasing behavior during livestream sales on digital technology platforms, focusing on psychological and technological factors influencing buying decisions. Using Structural Equation Modeling (SEM), the research identifies key relationships between consumer attitudes, trust, perceived behavioral control, subjective norms, and purchase intentions. The findings reveal that consumer attitudes towards livestream sales positively impact purchase intentions, with perceived usefulness, ease of use, and perceived behavioral control contributing significantly to positive attitudes. Conversely, perceived risk does not significantly affect attitudes, indicating its limited role in livestream contexts. Consumer trust also positively affects purchase intentions, influenced by perceived risk, livestreamer reputation, and subjective norms. Purchase intention is a critical predictor of actual buying behavior. The study highlights practical implications for businesses and livestreamers, including improving livestream quality, enhancing user experience, and building consumer trust. Recommendations are provided for both businesses and consumers to optimize livestream sales strategies. The study also outlines limitations, such as the sample size and geographic focus, and suggests future research directions to broaden the understanding of livestream purchasing behavior.

Keywords: Consumer Behavior, Digital Technology Platforms, Livestream Sales, Online Shopping, Purchase Intentions, Trust and Attitudes.

1. INTRODUCTION

The COVID-19 pandemic has accelerated the shift from traditional to online shopping, presenting new challenges and opportunities for businesses to leverage information technology. The rapid development of IT and digital platforms like Facebook, TikTok, YouTube, and Instagram has fueled the growth of e-commerce, particularly social commerce, driven by Web 2.0 and digital platforms. Utilizing online sales channels, especially through digital technology platforms, is crucial for businesses to adapt to this new context. This shopping model, combined with the trend of using webcasts, has expanded online shopping from traditional to real-time consumer models.

E-commerce companies are investing in webcast platforms, making "live broadcasting" + "e-commerce" a new trend in online shopping. Livestreaming offers a richer shopping experience through immediate communication features, combining the convenience of online shopping with an in-store presence. It has become a quick and convenient channel for consumers and a unique marketing strategy for businesses to enhance their competitive advantage.

Faced with fierce competition, businesses must develop strategies to retain customers and attract new consumer groups. Livestreaming programs, celebrity endorsements, unboxing videos, and attractive promotions are essential tools. Understanding the factors influencing shopping behavior in the context of livestreaming on digital platforms will help business managers make accurate and effective decisions. Online shopping via livestream allows consumers to interact and provide immediate feedback, enhancing the effectiveness of live content. Live broadcasting improves service efficiency, reduces sales costs, increases profits, and provides unique marketing benefits for businesses (L. Y. Chen, 2019).

According to statistics from the Ministry of Information and Communications, as of June 2024, the number of Internet users in Vietnam is nearly 80 million people (about 78.1% of the total population). In the first 6 months of 2024, digital economic growth is estimated to reach 22.4%, accounting for 18.3% of GDP. With such momentum, the goal set by the Party and State of Vietnam's digital economy to grow by 20% by 2025 will be achieved. The ICT industry has regained its pre-COVID-19 growth momentum, growing 26% over the same period last year. Total sales on 5 online retail platforms in the first 6 months of 2024 reaching over 97.000 billion VND, an increase of 80% over the same period in 2023. The growth rate of sales on online retail trading floors increased by 80% over the same period in 2023. According to Vietnam E-Commerce Association estimates, non-cash transactions are projected to surge by 50% in 2023 compared with 2022, hitting 11bn transactions. Internet payments climbed by 56% in volume terms and 5.8% in value, to nearly 2bn transactions. Mobile payments are tipped to jump by 67% in volume and 12% in value, approaching 7bn transactions. QR-code payments are forecast to almost triple in number to 183m, expanding by 74% in value and 172% in volume. The above figures have shown the potential and advantages of Vietnamese consumers in converting their shopping habits from direct to online, from cash to bank transfer, card swiping... Therefore, grasping this trend, many business account owners on digital platforms use livestream features to broadcast live videos, helping customers observe products more intuitively and build trust through better interaction. In this competitive online marketplace, businesses need

clever tactics and attractive promotions like celebrity endorsements, influencer partnerships, unboxing videos, and live broadcasts to attract consumers. Clarifying the factors influencing online shopping behavior while watching livestream sales videos will help business managers make informed decisions in developing livestream sales policies.

This study, based on the theoretical foundations of behavioral intention and consumer purchasing behavior, aims to investigate "Shopping Behavior When Watching Livestreams on Digital Technology Platforms in Vietnam." The research helps understand the interaction between sellers and buyers in the livestreaming environment and proposes specific policies and solutions for businesses to enhance online sales performance via livestream. The research seeks to answer the following questions:

Question 1: What factors influence online shopping behavior when watching livestreams on digital platforms of consumers in Vietnam? What is the specific impact of these factors?

Question 2: What management solutions are available for businesses to improve the effectiveness of livestream sales?

2. LITERATURE REVIEW

Research on livestream shopping behavior is rapidly evolving worldwide, with several key trends emerging that enhance our understanding and application of knowledge in specific contexts. First, studies are increasingly focusing on the diversity of contexts in livestream shopping behavior. Research is expanding beyond major markets like the US and China to examine the impact of cultural and geographical contexts on shopping behavior. Second, modern research pays attention to how specific social media platforms, such as Facebook, Instagram, and TikTok, influence livestream shopping behavior. This helps to better understand how the unique characteristics of each platform can impact consumer purchasing decisions. Third, the integration of technology and marketing is increasingly emphasized in research. The application of artificial intelligence, virtual reality, and other technologies to optimize user experience through livestreams is an important research direction. Finally, experimental research is becoming increasingly significant in measuring and analyzing livestream shopping behavior. This helps to establish causal relationships between influencing factors and purchasing decisions, thereby providing a more solid foundation for strategic decision-making.

To date, numerous studies have been conducted on online shopping behavior worldwide. Notable studies include Li and Zhang (2002), "Customer Attitudes towards Online Shopping," which introduced and explained a model of customer behavior in online shopping, including commonly used dependent and independent variables in online consumer behavior research. Sultan and Uddin (2011) investigated customer attitudes towards online shopping in Gotland, concluding that the most significant factor influencing online shopping behavior is website design, followed by convenience, time savings, and security. Javadi et al. (2012), in "Analyzing the Factors Affecting Online Shopping Behavior Intention," used a model to test the impact of perceived risk, infrastructure, and return policies on consumer attitudes towards online shopping.

In the field of livestream shopping behavior research, several important studies have significantly contributed to the development of a general knowledge base. Wang, Lee, and Lee (2018) investigated factors affecting product purchase intentions in online shopping on Taobao, demonstrating that source attractiveness has a significant impact on product attitudes for hedonic versus practical products. Sun et al. (2019) developed a theoretical model from the perspective of IT interactivity, studying how livestreaming affects customer purchase intentions on e-commerce websites in China. Li and Zhang (2020) evaluated live e-commerce through livestreaming in China, focusing on the prospects and challenges of live streaming e-commerce in the Chinese context. Deng, Li, and Wei (2020), in "Livestream Shopping: A Conceptualization and Research Agenda," developed a theoretical framework and proposed a research agenda for the live shopping model. Wu, Li, and Liang (2020), in "Live Streaming Commerce: Consumer Purchasing Behavior and Perceived Efficiency," surveyed consumer purchasing behavior in live streaming commerce. Xie, Chen, and Mei (2021), in "Live Commerce: A Systematic Review and Future Research Agenda," conducted a detailed and systematic review of live commerce. Zhang et al. (2022), in "How to Retain Customers: Understanding the Role of Trust in Live Streaming Commerce with a Socio-Technical Perspective," developed a comprehensive theoretical model to explain the impact of social and technical factors on trust and continued usage intentions in the context of live streaming commerce.

From the review of the above literature, it is evident that research into the factors affecting online shopping behavior through livestreaming has been addressed by many researchers. However, previous studies have mainly focused on online shopping behavior through livestreaming on e-commerce web platforms or on specific product categories, predominantly fashion apparel. There is a lack of more in-depth studies with broader scope and samples, including the influencing factors of online shopping behavior when watching livestream sales videos on digital technology platforms. Recognizing these research gaps, the author aims to explore the factors influencing online shopping behavior when watching livestream sales videos on digital technology platforms in Vietnam, to provide a clearer and more specific understanding of these factors, and to propose strategic recommendations for livestreamers, online sellers, and business managers to effectively implement livestream sales.

3. THEORETICAL FRAMEWORK

3.1. Consumer Purchasing Behavior When Watching Livestreams

Online shopping behavior refers to the process by which consumers use digital platforms to search, compare, and conduct transactions for products or services over the internet. E-commerce, where transactions occur online rather than in physical stores, has become an essential part of the modern economy. This behavior allows consumers to easily compare prices among different suppliers, read reviews and comments from other consumers, and make purchases from anywhere and at any time. This provides significant convenience, along with secure online payment methods and fast delivery services, enhancing the positive consumer experience.

Purchasing behavior while watching livestreams is a relatively new concept and currently lacks a standard definition in academic circles. According to Tan Yuli (2017), livestream e-commerce is a business model that combines traditional e-commerce platforms with live broadcasting technology. Jia Xiaofeng (2019) expands on this concept by emphasizing that the model not only includes elements of e-commerce but also integrates characteristics of live broadcasting media. In this model, sellers use livestreams to showcase products and services, provide detailed information, and interact directly with customers through features such as comments and real-time feedback. This model allows customers to participate in the purchasing decision process instantly, creating a more personalized and intimate shopping experience.

Digital platforms and livestream selling are crucial tools for conducting purchasing behavior when watching livestreams. Digital platforms are systems that enable users to interact, share information, and conduct online transactions. These platforms provide an environment for communication and e-commerce activities, from sharing information to making purchases. They facilitate consumer connections with products, services, and sellers through social network mechanisms and mobile applications. Popular digital platforms today include e-commerce websites and apps like Amazon and Shopee, as well as social media platforms like Facebook and Instagram.

Livestreaming on digital platforms provides a real-time interactive environment between sellers and consumers. Businesses can use livestreams to promote products, demonstrate features, and answer customer questions in real-time. The combination of live video and the interactive features of social media creates a unique and engaging shopping experience. Livestreams often include promotional strategies such as discounts and giveaways to attract attention and stimulate purchasing behavior. In addition to enhancing trust and closeness with the brand, livestreaming also provides businesses with more effective ways to promote their products.

3.2. Theory of Reasoned Action (TRA)

The Theory of Reasoned Action (TRA) is a theoretical model in the field of social psychology proposed by Martin Fishbein and Icek Ajzen in the 1960s and later developed. This model focuses on predicting and explaining human behavior, especially shopping and consumption behavior. TRA is considered one of the pioneering and foundational theories in social psychology research in general and consumer behavior in particular (Püschel, Mazzon, & Hernandez, 2010). According to this theory, behavioral intention is the key determinant of a customer's behavior. Thus, instead of focusing on studying consumer behavior directly, TRA emphasizes studying behavioral intentions.

The Theory of Reasoned Action (TRA) can be effectively applied to explain online shopping behavior when watching livestreams. Researchers can use this model to determine whether consumers have the intention to shop after watching a livestream, which is crucial for predicting actual behavior. Additionally, by observing and recording actual online shopping behavior of consumers, the accuracy of the model can be assessed. Yoh et al. (2003) argue that evaluating consumer attitudes towards online shopping is essential. Factors such as product quality, livestream performance, and online shopping experience will influence their attitudes. Thus, if consumers rate the product quality highly and find the way the seller introduces the product during the livestream appealing, their attitude towards online shopping might be positive.

TRA can also help researchers evaluate the importance of subjective norms on shopping decisions. Influence from family, friends, or celebrities on livestream platforms can play a significant role. David Gefen et al. (2003) suggest that opinions from friends, family, or influencers can strongly impact consumers' online shopping decisions. If there are celebrities or close friends who have had positive experiences with online shopping while watching livestreams, subjective norms will increase, and the likelihood of consumers engaging in similar behavior will be high.

3.3. Theory of Planned Behavior (TPB)

The Theory of Planned Behavior (TPB) (Icek Ajzen, 1991) is an extension of the earlier Theory of Reasoned Action (TRA) developed by Ajzen and Fishbein (1980), which has a broader applicability and predictive capability. Both theories apply to voluntary behaviors supported by intentions and rational thoughts. The Theory of Planned Behavior (TPB) can be effectively applied to understand and predict online shopping behavior when watching livestreams. In this way, researchers can identify the influence of attitudes, subjective norms, and perceived behavioral control on shopping intentions and actual behavior. Consumer attitudes involve evaluating the quality of the product, the livestream experience, and the reliability of the seller, which can lead to a positive

attitude towards online shopping. Subjective norms involve opinions from friends, family, and relatives, which can create social pressure and increase consumers' shopping intentions. Perceived behavioral control involves factors like easy access, convenience of the payment process, and reliability of product quality, which can affect perceived control and, consequently, the likelihood of engaging in online shopping behavior.

The Theory of Planned Behavior (TPB) extends the predictive model of behavior and is well-suited to explain online shopping decisions when watching livestreams, providing a comprehensive view of the influence of psychological and social factors on shopping behavior. According to TPB, positive attitudes, pressure from subjective norms, and perceived behavioral control can together predict shopping intentions.

3.4. Technology Acceptance Model (TAM)

The Technology Acceptance Model (TAM) is a model explaining the acceptance and use of technology. The Technology Acceptance Model (TAM) was developed by F. D. Davis (1986) based on the Theory of Reasoned Action. This model is designed to predict the acceptance of an information system or computer network and to identify necessary modifications for user acceptance and trust. In the context of online shopping while watching livestreams, perceived usefulness can be measured by evaluating how much consumers believe that shopping via livestream provides value and benefits to them. Factors such as product quality, seller reliability, and interactivity through livestreams can influence the perception of usefulness. In the model of online shopping while watching livestreams, perceived ease of use can be measured by assessing how simple and convenient the online shopping process through livestreams is. A user-friendly interface that is easy to use and understand can enhance the perception of ease of use for consumers watching livestreams.

Thus, according to the Technology Acceptance Model, the intention to shop online while watching livestreams is a result of perceived usefulness and perceived ease of use. If consumers find the product useful and the shopping process easy, they are more likely to have the intention to shop. Consumer purchasing behavior after watching a livestream can be monitored to evaluate the success of the online shopping model through livestreams and to adjust the factors related to perceived usefulness and perceived ease of use if necessary.

4. MODELS AND RESEARCH HYPOTHESES

4.1. Consumer Attitudes and Purchase Intentions When Watching Livestreams

Attitude is defined as an individual's evaluation of the outcomes derived from performing a behavior (Icek Ajzen, 1991). In the context of online shopping, attitude refers to the positive or negative evaluations consumers have about using the Internet to purchase goods or services from retail websites (Lin, 2007). Consumer attitudes influence their intentions (Icek Ajzen & Fishbein, 1975). In online shopping, consumer attitudes towards online shopping have been shown to positively influence their purchase intentions (Yoh, Damhorst, Sapp, Laczniak, & Marketing, 2003). The proposed research hypothesis is:

H₁: Consumer attitudes positively influence purchase intentions when watching livestreams of online sales.

4.2. Perceived Usefulness and Consumer Attitudes

Perceived usefulness is defined as "the degree to which a person believes that using a specific system will enhance their performance on the job" (Davis, 1989, p. 320). In the context of e-commerce, perceived usefulness refers to the extent to which a consumer believes that online shopping will enhance their efficiency in purchasing goods or services (Shih, 2004, p. 354). There is solid evidence that perceived usefulness affects online shopping intentions through consumer attitudes (Barkhi et al., 2008; L.-D. Chen & Tan, 2004; Vijayasathy, 2002). The proposed research hypothesis is:

H₂: Perceived usefulness positively influences consumer attitudes towards purchasing when watching livestreams of online sales.

4.3. Perceived Ease of Use and Consumer Attitudes

Perceived ease of use is defined as "the degree to which a person believes that using a specific system would be free of effort" (F. D. J. M. q. Davis, 1989). In the context of online shopping, perceived ease of use can be defined as the extent to which consumers believe they do not need to exert effort when shopping online (Lin, 2007). Similar to perceived usefulness, the role of perceived ease of use has been shown to significantly influence online shopping intentions through attitudes (Barkhi et al., 2008; L.-D. Chen & Tan, 2004). The proposed research hypothesis is:

H₃: Perceived ease of use positively influences consumer attitudes towards purchasing when watching livestreams of online sales.

4.4. Perceived Risk and Consumer Attitudes

Perceived risk is defined as "the customer's perception of the probability of gain and loss in transactions with a store/distributor" (Mayer, Davis, & Schoorman, 1995). In e-commerce, customers' perceived risk has an inverse relationship with their attitudes towards virtual stores (Jarvenpaa et al., 2000). The proposed research hypothesis is:

H1c: Perceived risk negatively affects consumer attitudes towards purchasing when watching livestreams of online sales.

4.5. Perceived Behavioral Control and Consumer Attitudes

Barkhi et al. (2008) demonstrated that perceived behavioral control significantly affects consumer attitudes towards online shopping. If consumers perceive high control over their behavior, they feel they can make better choices, and vice versa (Barkhi et al., 2008). The proposed research hypothesis is:

H1d: Perceived behavioral control positively influences consumer attitudes towards purchasing when watching livestreams of online sales.

4.6. Trust and Consumer Purchase Intentions

Trust is defined as “the expectation that individuals or companies we interact with will not exploit the advantages to make us dependent on them. It is the belief that stakeholders will act ethically, reliably, in accordance with social norms, and will fulfill their commitments” (David Gefen, 2003). Previous studies have shown that consumer trust in an online retail website is a significant factor affecting their online shopping intentions (David Gefen et al., 2003; David Gefen, 2003; Paul A Pavlou, 2003). Lack of trust has been recognized as one of the main reasons preventing consumers from engaging in e-commerce (Jarvenpaa et al., 2000; Monsuwé, Dellaert, & De Ruyter, 2004). The proposed research hypothesis is:

H2: Consumer trust positively influences purchase intentions when watching livestreams of online sales.

4.7. Perceived Risk and Consumer Trust

On the other hand, Chang & Chen (2008) demonstrated that perceived risk has an inverse relationship with trust. Perceived risk can arise from various sources and negatively impact consumer trust. If consumers perceive risks related to product quality, they may distrust the information conveyed in livestream videos. Perceived risk may increase if consumers feel that return or refund policies are unclear or unfair. Therefore, the proposed hypotheses are:

H2a: Perceived risk negatively impacts consumer trust in purchasing when watching livestreams of online sales.

4.8. Perceived Reputation and Consumer Trust

The reputation of an online retailer is similar to a brand's reputation; it includes the name, logo, design, and other identifying marks of products among different suppliers (Bennett, Gabriel, & Marketing, 2001). A retailer's reputation is not only related to the business's image but also depends on customer reviews and perceptions (Bennett et al., 2001). Previous studies have shown that consumers trust online retail websites if they perceive the business to have a good reputation (Bennett et al., 2001; Jarvenpaa et al., 2000; Teo & Liu, 2007). Therefore, the proposed research hypothesis is:

H2b: Perceived reputation of the livestreamer/business positively influences consumer trust.

4.9. Subjective Norms and Consumer Trust

Subjective norms can be described as an individual's perception of the social pressures to perform or not perform a behavior (Icek Ajzen, 1991). Opinions from friends, family, colleagues, and mass media can influence consumer trust in online providers (David Gefen et al., 2003). Therefore, the proposed research hypothesis is:

H2c: Subjective norms positively influence consumer trust.

4.10. Perceived Behavioral Control and Consumer Purchase Intentions

Perceived behavioral control is defined as an individual's perception of the ease or difficulty of performing a behavior (Icek Ajzen, 1991). PBC reflects the degree of control over performing a behavior rather than the outcome of the behavior (Icek Ajzen, 2002). In the context of online shopping, perceived behavioral control describes consumers' perceptions of the availability of necessary resources, knowledge, and opportunities to engage in online shopping (Lin, 2007, p. 434). In online shopping, perceived behavioral control has been shown to positively affect consumers' online purchase intentions (Lin, 2007). Therefore, the proposed research hypothesis is:

H3: Consumers' perceived behavioral control positively influences purchase intentions when watching livestreams of online sales.

4.11. Subjective Norms and Consumer Purchase Intentions

Additionally, previous studies suggest a positive relationship between subjective norms and intentions (Barkhi et al., 2008; Bhattacharjee et al., 2000; Hansen et al., 2004; Vijayarathay, 2002; Yoh et al., 2003). Therefore, the proposed research hypothesis is:

H4: Consumers' subjective norms positively influence their purchase intentions when watching livestreams of online sales.

4.12. Perceived Behavioral Control and Consumer Purchase Behavior

Furthermore, in the TPB model, perceived behavioral control has a dual role, influencing both intentions and

actual behavior. The dual role of perceived behavioral control is supported by Taylor & Todd (1995), Lin (2007), and Pavlou & Fygenson (2006), who agree that neglecting perceived behavioral control could lead to an incomplete/insufficient understanding of consumer behavior. Therefore, the proposed research hypothesis is:

H₆: Consumers' perceived behavioral control positively influences their purchase behavior when watching livestreams of online sales.

4.13. Intentions and Consumer Purchase Behavior

According to the TPB model, intentions determine a person's actual behavior. Intentions are seen as comprising motivational factors that influence an individual's behavior. Furthermore, intentions are considered as precursors and the best predictors of behavior. Usage intention is a determinant of actual behavior. The proposed hypothesis is:

H₈: Online purchase intentions positively influence purchase behavior when watching livestreams of online sales.

Additionally, recent studies have shown that consumer-generated information has become a significant influence on consumer behavior, such as purchase decisions. Online Consumer Reviews (OCR) are part of consumer-generated information after purchasing the target product on a website (Lee et al., 2011). OCR contains product information and recommendations from the consumers' perspective (Park et al., 2007). Recent studies have explored how OCR, as electronic word-of-mouth (eWOM), affects consumer behavior (Brown & Reingen, 1987; Chatterjee, 2001; Chen & Xie, 2008). People often make purchase decisions based on consumer-generated information on the Internet (Godes & Mayzlin, 2004). Based on these perspectives, it is proposed that after the formation of online purchase intentions through livestreams, OCR will play a moderating role in translating intentions into purchase behavior. Therefore, the proposed hypothesis is:

H₉: Online consumer reviews play a moderating role in the relationship between purchase intentions and purchase behavior when watching livestreams of online sales.

Thus, there are many factors that influence and shape consumer purchase behavior when watching livestreams of online sales. Each factor has varying degrees of impact and does not act in isolation but is interconnected. Therefore, understanding the role of each factor under specific conditions and times is necessary to enhance positive factors and minimize negative ones affecting consumer purchase behavior when watching livestreams of online sales, thus providing a basis for proposing management and marketing solutions to boost sales when watching livestreams. Therefore, the author proposes the research model as follows:

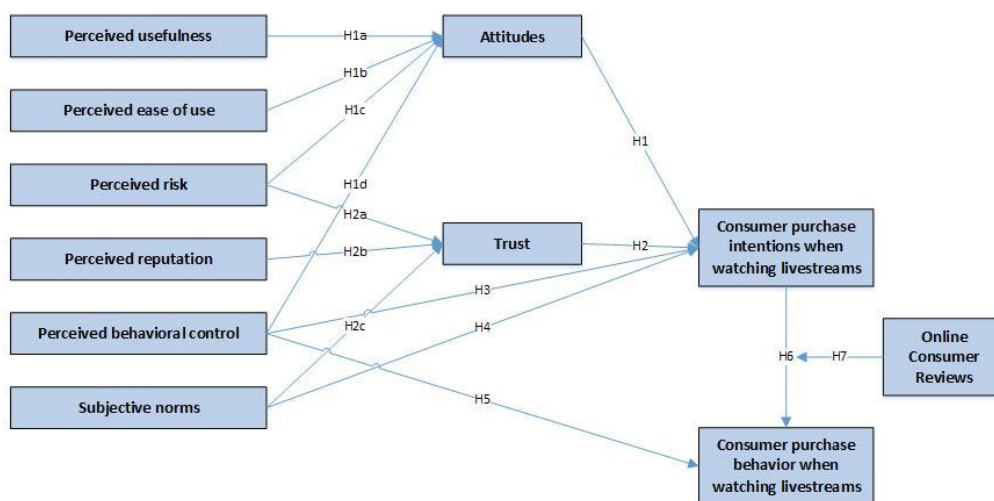

Figure 1: Research model.

5. RESEARCH METHODOLOGY

This study employs a combination of qualitative and quantitative research methods to collect multidimensional data on online shopping behavior during livestreaming. This combination enhances the accuracy and reliability of the research findings.

5.1. Qualitative Research Method

The qualitative research method is used to explore and identify the factors affecting online shopping intentions and behavior when watching livestream videos. Initially, a research model based on the Technology Acceptance Model (TAM) is developed to identify influencing factors and the observed variables to be measured. The model and measurement scales are then adjusted through expert consultations and in-depth interviews with a sample of consumers, including students, administrative staff, and frequent social media users. This process clarifies the influencing factors and tailors the research model to the Vietnamese context.

5.2. Quantitative Research Method

The quantitative research method is conducted through a survey using a questionnaire designed based on the results from the qualitative research. The questionnaire is developed using measurement scales validated in reputable journals, ensuring that the questions are clear and understandable. The sample size is determined using the formula $n = 8m + 50$, where m represents the number of observed variables, requiring a minimum sample size of 450 for this study. A convenience sampling method is applied to optimize access and reduce costs, though care must be taken to minimize bias.

The survey is conducted both online and in person to ensure the representativeness and diversity of the sample. The survey targets consumers across various digital technology platforms in Vietnam. During data collection, invalid responses, such as excessively short or long answers, or those with logical errors, will be excluded. Additionally, the reliability of the scales will be tested using Cronbach's Alpha and exploratory factor analysis (EFA) before conducting confirmatory factor analysis (CFA) and structural equation modeling (SEM) using AMOS software.

To ensure the accuracy and reliability of the research results, the following steps will be undertaken. Firstly, the questionnaire will be carefully designed to ensure that the questions are clear and comprehensible. During data processing, data errors will be checked and removed, including invalid cases or those with logical errors. Finally, methods for detecting bias and potential errors will be applied to ensure that the collected data is accurate and valid.

6. RESEARCH RESULTS

6.1. Descriptive Statistics

In this section, the author will present the descriptive statistical results regarding the demographic characteristics of the survey sample. A total of 475 surveys were collected from both online and offline methods, of which 463 valid responses were included in the analysis. The demographic information includes gender, age, educational level, income, daily internet usage time, and frequency of purchasing while watching livestreams. The aim of analyzing these demographic characteristics is not only to better understand the survey participants but also to provide a foundation for deeper analysis of online shopping behavior during livestreams. The results of the descriptive statistics on the demographic characteristics of the survey sample are summarized in Table 1 as follows:

Table 1: Demographic Characteristics of the Survey Sample.

No.	Sample Information	Quantity (People)	Percentage (%)
1	Gender	463	100.0
	- Male	190	41
	- Female	273	59
2	Age	463	100.0
	- Under 18 years	45	9.7
	- 18 - 34 years	199	43
	- 34 - 55 years	182	39.3
	- Over 55 years	37	8
3	Educational Level	463	100.0
	- Below High School	46	9.9
	- High School	55	12
	- Intermediate/College	102	22
	- University	176	38
	- Postgraduate	84	18.1
4	Average Monthly Income	463	100.0
	- Below 5 million VND	50	10.8
	- 5 to 10 million VND	182	39.3
	- Over 10 to 15 million VND	165	35.6
	- Over 15 to 20 million VND	46	9.9
	- Over 20 million VND	20	4.3
5	Daily Internet Usage Time	463	100.0
	- Less than 1 hour	29	6.3
	- 1 to 3 hours	66	14.3
	- Over 3 to 5 hours	106	22.9
	- Over 5 to 7 hours	135	29.2
	- Over 7 hours	127	27.4
6	Frequency of Purchasing While Watching Livestream	463	100.0
	- Never	15	3.2
	- Rarely (less than 1 time/month)	135	29.2
	- Occasionally (1-2 times/month)	144	31.1
	- Frequently (3-4 times/month)	121	26.1
	- Very frequently (more than 4 times/month)	48	10.4

Among the 463 survey participants, there is a noticeable gender discrepancy. Specifically, there are 190 males (41%) and 273 females (59%). This indicates that females are more likely to be interested in and participate in

surveys about online shopping behavior during livestreams than males. Regarding the age of the survey participants, they are divided into four groups, with the 18 to 34 age group comprising the largest proportion. This suggests that this age group is the most engaged in online shopping through livestreams. Most participants have educational levels of at least university, accounting for 56.1% of the total, indicating a significant interest in online shopping through livestreams among those with higher education. For average monthly income, the majority of participants fall into the income ranges of 5 to 10 million VND and 10 to 15 million VND, reflecting a diverse income range among the participants. Regarding daily internet usage, the survey shows that most participants spend over 5 hours online each day, indicating high internet use suitable for accessing online sales livestreams. For the frequency of purchasing while watching livestreams, the highest proportion of participants shop occasionally, indicating a trend of not frequent but still significant participation in this activity.

The descriptive statistical analysis of demographic variables reveals diversity in gender, age, educational level, income, internet usage time, and frequency of purchasing while watching livestreams among the survey participants. This result provides a comprehensive view of the consumer profile in the study and will serve as a crucial basis for further analyses.

6.2. Statistics on Product Types Purchased During Livestreams

This section presents the descriptive statistical results on the types of products that consumers frequently purchase or plan to purchase while watching online sales livestreams. In addition to questions about basic demographic information, the survey participants were asked to select all product types that match their shopping habits with the question: "Which types of products do you usually buy (or tend to buy) while watching online sales livestreams? (Multiple answers possible)." The survey resulted in 1,372 selections from 463 respondents, as detailed below:

Table 2: Statistics on Product Types Purchased During Livestreams.

No.	Product Type	Quantity (Times)	Percentage (%)
1	Fashion (clothing, shoes, accessories)	344	25.1%
2	Cosmetics and beauty products	269	19.6%
3	Household items	122	8.9%
4	Electronics (phones, laptops, tablets)	211	15.4%
5	Food and beverages	59	4.3%
6	Books and stationery	64	4.7%
7	Toys and products for children	83	6.0%
8	Sports and travel products	151	11.0%
9	Other	69	5.0%
	Total	1372	100.0%

For fashion items (clothing, shoes, accessories), the number of selections reached 344 (25.1%). This indicates a significant interest in fashion products when shopping online through livestreams. This is understandable as fashion is one of the most popular product categories purchased online, reflecting the highest percentage among consumer choices. For cosmetics and beauty products, there were 269 selections, accounting for 19.6% of the total choices. Thus, it can be observed that cosmetics and beauty products are also favored by consumers while watching livestreams, with more than half of the survey participants expressing this preference. Although household items do not have as high a percentage as fashion and cosmetics, they are still among the products frequently chosen by consumers during livestreams, with 122 selections, making up 8.9%. Electronic devices (phones, laptops, tablets, etc.) are also commonly purchased through livestreams, showing consumers' interest in technology products when shopping online. Food and beverages account for a lower percentage compared to other product types, but some consumers still opt to purchase these products via livestreams. Additionally, books and stationery; toys and products for children; and sports and travel products are also purchased through livestreams, though their proportions are not as high, they still show a notable presence. Moreover, there were 69 selections (5%) for other products, including DIY items (materials and tools for crafts, art, gardening, etc.), health care products (nutritional supplements, tonics, home medical devices such as blood pressure monitors, blood glucose meters, massage machines, etc.), and online services and courses.

Overall, the statistical results indicate that fashion products, cosmetics, and electronics are the most frequently purchased items by consumers while watching online sales livestreams. Other products such as household items, food and beverages, books and stationery, toys and products for children, and sports and travel products also receive a certain level of consumer interest. This reflects the diversity in online shopping habits of consumers when watching livestreams.

6.3. Reliability Assessment of the Measurement Scales Using Cronbach's Alpha

In this study, a Cronbach's Alpha coefficient greater than 0.6 and item-total correlation coefficients greater than 0.3 are considered acceptable. Conversely, variables with a Cronbach's Alpha coefficient less than 0.6 and item-total correlation coefficients below 0.3 will be excluded.

The results of the Cronbach's Alpha test were conducted for each component in the research model. The

reliability testing of the component scales is detailed as follows: The results show that the scales for HI, SD, RR, DT, KS, CQ, TD, NT, YD, and HV all have a general Cronbach's Alpha coefficient greater than 0.6, with no observation showing an item-total correlation coefficient less than 0.3. Additionally, removing any variable would result in a lower Cronbach's Alpha coefficient than the general reliability coefficient. Therefore, these scales meet the reliability requirements for further analysis. Specifically, the DG scale, measured by 7 observed variables (DG1-DG7), initially had a general reliability coefficient of $0.817 > 0.6$. However, the first test revealed that the variable DG7 had an item-total correlation coefficient of $-0.77 < 0.3$. Consequently, the author removed variable DG7 and conducted a second test. The results of the second test showed that the reliability coefficient for the DG scale was 0.878, with no observation having an item-total correlation coefficient below 0.3, and removing any variable would result in a lower Cronbach's Alpha coefficient than the general reliability coefficient. Thus, the DG scale, including the remaining 6 observations, meets the reliability requirements for further analysis. The results of the reliability tests for the component scales in the model are detailed in Table 3:

Table 3: Results of the Reliability Testing of Measurement Scales.

Factor/Variable	Number of Observations	Code	Item-Total Correlation	Cronbach's Alpha if Item is Deleted	Cronbach's Alpha
Perceived Usefulness (HI)	5	HI1	0.556	0.832	0.841
		HI2	0.639	0.810	
		HI3	0.661	0.804	
		HI4	0.664	0.803	
		HI5	0.708	0.790	
Perceived Ease of Use (SD)	4	SD1	0.693	0.872	0.884
		SD2	0.733	0.858	
		SD3	0.781	0.839	
		SD4	0.792	0.835	
Perceived Risk (RR)	5	RR1	0.659	0.829	0.856
		RR2	0.696	0.820	
		RR3	0.677	0.825	
		RR4	0.652	0.831	
		RR5	0.668	0.827	
Reputation (DT)	4	DT1	0.629	0.796	0.829
		DT2	0.627	0.796	
		DT3	0.672	0.776	
		DT4	0.693	0.766	
Perceived Behavioral Control (KS)	4	KS1	0.756	0.830	0.875
		KS2	0.754	0.831	
		KS3	0.722	0.844	
		KS4	0.695	0.855	
Subjective Norm (CQ)	4	CQ1	0.678	0.766	0.825
		CQ2	0.593	0.805	
		CQ3	0.663	0.773	
		CQ4	0.666	0.772	
Attitude (TD)	3	TD1	0.641	0.739	0.803
		TD2	0.672	0.708	
		TD3	0.635	0.745	
Trust (NT)	5	NT1	0.724	0.868	0.890
		NT2	0.723	0.868	
		NT3	0.753	0.861	
		NT4	0.755	0.860	
		NT5	0.703	0.872	
Online Consumer Reviews (DG)	6	DG1	0.668	0.860	0.878
		DG2	0.717	0.852	
		DG3	0.683	0.858	
		DG4	0.629	0.866	
		DG5	0.663	0.861	
		DG6	0.748	0.846	
Online Shopping Intention During Livestreams (YD)	4	YD1	0.773	0.817	0.871
		YD2	0.665	0.859	
		YD3	0.720	0.837	
		YD4	0.744	0.827	
Online Shopping Behavior During Livestreams (HV)	5	HV1	0.814	0.926	0.937
		HV2	0.849	0.919	
		HV3	0.822	0.925	
		HV4	0.795	0.929	
		HV5	0.879	0.914	

Through the analysis of Cronbach's Alpha reliability, it was concluded that all 11 measurement scales used meet the reliability requirements for the subsequent analysis steps.

6.4. Exploratory Factor Analysis (EFA)

6.4.1. EFA for Independent, Mediating, and Dependent Variables

The results of the EFA for the variables HI, SD, DT, RR, KS, CQ, TD, NT, YD, and HV indicate that the analysis is quite good. The KMO coefficient is $0.882 > 0.5$, indicating that the dataset is suitable for factor analysis (Kaiser, 1974). Bartlett's Test is used to examine whether the observed variables in the factors are correlated with each other. The value is satisfactory when the Sig value of the test is $0.000 < 0.05$, meaning the observed variables are correlated and suitable for factor analysis using EFA (Table 4).

Table 4: Results of EFA for independent, mediating, and dependent variables.

Evaluation Factors	Test Values
KMO Coefficient	0.882
Sig Value in Bartlett's Test	0.000
Total Variance Explained	70.551%
Eigenvalue	1.172

Hair et al. (2014) suggested that only factors with an eigenvalue (also known as latent roots) of 1 or higher are meaningful and should be retained. The stopping point for factor analysis is based on the Eigenvalue coefficient, with the optimal number of factors chosen when this coefficient has the smallest value > 1 and the cumulative percentage is greater than 50% (Joe F Hair Jr et al., 2014). Based on these conditions, the Total Variance Explained table shows that starting from the 10th factor, the eigenvalue is 1.172, which is greater than 1, and the total variance explained reaches 70.551%, which is greater than 50%. Thus, 10 factors explain 70.551% of the variance in the data of the 43 observations of the independent, mediating, and dependent variables involved in the EFA.

6.4.2. EFA For the Moderator Variable

The EFA results for the DG (Online Consumer Reviews) variable indicate that the analysis is quite good. The KMO coefficient is $0.717 > 0.5$, indicating that the dataset is suitable for factor analysis (Kaiser, 1974). Bartlett's Test is also satisfactory when the Sig value of the test is $0.000 < 0.05$, meaning the observed variables are correlated and suitable for factor analysis using EFA. The results also show that one factor is extracted with an Initial Eigenvalue of $3.732 > 1$, and the total variance explained is 62.2%, which is greater than 50%, indicating that the extracted factor in the EFA reflects 62.2% of the variance of the 6 observed variables. The rotated matrix results show that the 6 observed variables are grouped into a single factor, and all 6 observed variables have Factor Loading coefficients greater than 0.5. Therefore, all these observed variables are retained for the subsequent analysis steps.

Table 5: Results of Exploratory Factor Analysis (EFA) for the Moderator Variable.

Evaluation Factors	Test Values
KMO Coefficient	0.717
Sig Value in Bartlett's Test	0.000
Total Variance Explained	62.2%
Eigenvalue	3.732

6.5. Confirmatory Factor Analysis (CFA)

The CFA method allows testing the theoretical structure of the measurement scales, including the relationships between measured variables, without being affected by measurement errors. The results after performing CFA show: $\text{CMIN}/df = 1.672$ ($\text{CMIN}/df \leq 3$); $\text{GFI} = 0.880$ ($0.8 < \text{GFI} < 0.9$); $\text{CFI} = 0.949$ ($\text{CFI} \geq 0.9$); $\text{TLI} = 0.944$ ($\text{TLI} \geq 0.9$); $\text{RMSEA} = 0.038$ ($\text{RMSEA} \leq 0.6$); $\text{PCLOSE} = 1.000$ ($\text{PCLOSE} \geq 0.05$). It can be seen that the criteria used in the study to assess the unidimensionality of the scale fit all the established criteria. Therefore, the definitions used in the study ensure unidimensionality, and the research model is suitable for market data. Besides testing the unidimensionality of the scale, the study also conducts additional tests for convergence, discrimination, and reliability of the scales used by the author to avoid potential errors, contributing to both theoretical and practical aspects.

Table 6: Results of Confirmatory Factor Analysis (CFA).

Indicator	Standard	Result	Evaluation
CMIN/df	≤ 3	1.672	Good
GFI	$0.8 < \text{GFI} < 0.9$	0.880	Acceptable
CFI	≥ 0.9	0.949	Good
TLI	≥ 0.9	0.944	Good
RMSEA	≤ 0.6	0.030	Good
PCLOSE	≥ 0.05	1.000	Good

Table 7: Results of CR, AVE, MSV, and SQRTAVE Evaluation.

	CR	AVE	MSV	MaxR(H)	NT	HV	RR	SD	HI	KS	YD	CQ	DT	TD
NT	0.890	0.619	0.211	0.891	0.787									
HV	0.938	0.751	0.398	0.942	0.409***	0.867								
RR	0.856	0.544	0.358	0.857	-0.333***	-0.598***	0.737							
SD	0.885	0.659	0.098	0.901	0.083	0.312***	-0.225***	0.812						
HI	0.842	0.517	0.057	0.852	0.239***	0.174**	-0.188***	0.068	0.719					
KS	0.876	0.638	0.154	0.880	0.195***	0.392***	-0.329***	0.108*	0.067	0.799				
YD	0.873	0.634	0.243	0.886	0.460***	0.493***	-0.281***	0.155**	0.080	0.286***	0.796			
CQ	0.825	0.543	0.398	0.833	0.429***	0.631***	-0.437***	0.148**	0.078	0.267***	0.352***	0.737		
DT	0.830	0.550	0.129	0.833	0.295***	0.359***	-0.263***	0.082	0.091	0.270***	0.189***	0.234***	0.741	
TD	0.804	0.578	0.087	0.807	0.089	0.158**	0.002	0.166**	0.139*	0.173**	0.294***	0.128*	0.012	0.760

The table "Results of CR, AVE, MSV, and SQRTAVE Evaluation" shows that $MSV < AVE$ for all constructs. Additionally, the SQRTAVE values are greater than the inter-construct correlations. Therefore, we can conclude that the criteria for evaluating discriminant validity are met. Consequently, the CFA results show that the constructs meet the requirements for validity and reliability, and the number of factors and measured variables on these factors fit the theoretical foundation established beforehand. Thus, the measurement scales are suitable for use in structural equation modeling (SEM) analysis.

6.6. Structural Equation Modeling (SEM)

From the table below, we see that the P-value obtained is 0.000, which is less than 0.05, meeting the set criteria. The CMIN/df, CFI, TLI, RMSEA, and PCLOSE indices are 1.969, 0.925, 0.919, 0.046, and 0.984, respectively, satisfying the model fit measurement criteria. The GFI is 0.861, which is acceptable given the research context and sample size.

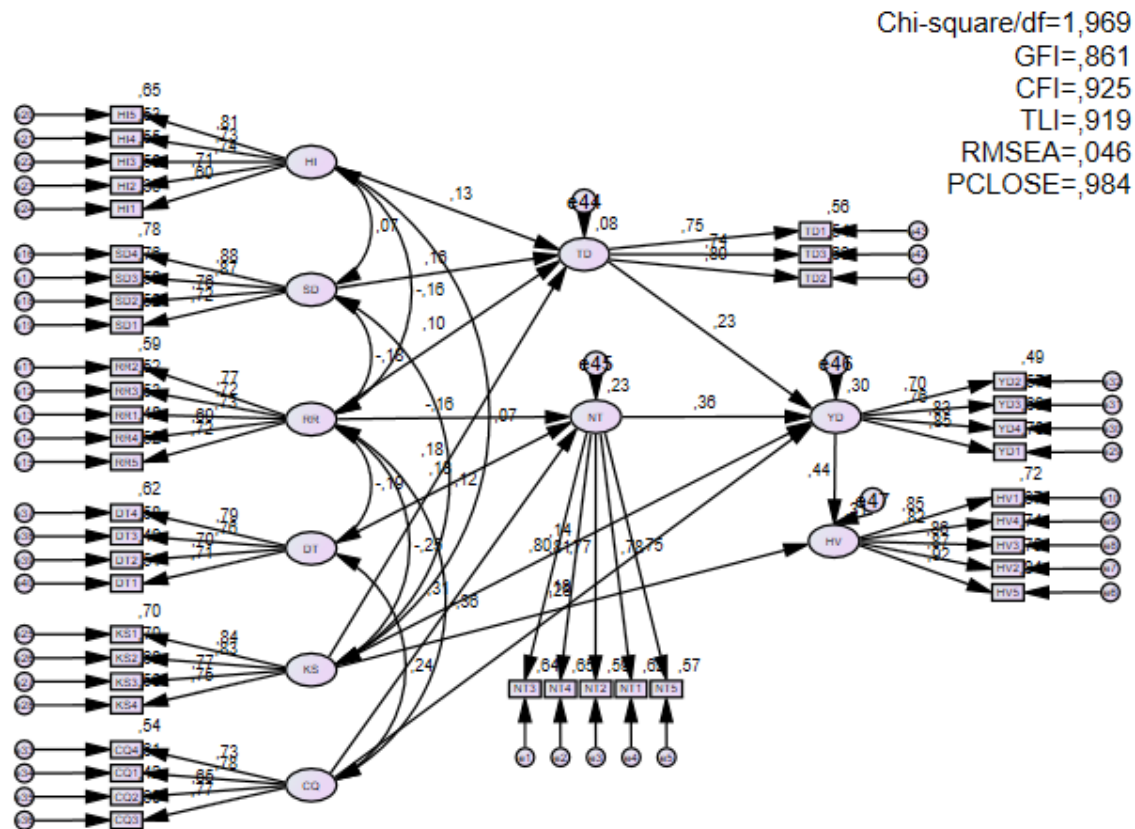

Figure 2: SEM Linear Regression Analysis Results.

Using statistical indicators, the author tests the proposed research hypotheses. The SEM analysis results indicate that the impact relationship between RR and TD is not statistically significant ($p > 0.05$), while the remaining relationships are significant. Specifically, the remaining hypotheses are statistically significant with 95% confidence ($p < 0.05$). Apart from the inverse relationship between RR and NT with a negative estimate (-0.154), the remaining relationships have a positive impact on each other due to positive estimates.

Table 8: Hypothesis Testing Results.

Hypothesis	Correlation	Estimate	S.E	C.R	P	Result
H1	YD <--- TD	0.279	0.061	4.557	***	Accepted
H1a	TD <--- HI	0.106	0.045	2.360	0.018	Accepted
H1b	TD <--- SD	0.093	0.031	2.967	0.003	Accepted
H1c	TD <--- RR	0.072	0.041	1.749	0.080	Rejected ($p > 0.05$)
H1d	TD <--- KS	0.114	0.036	3.151	0.002	Accepted
H2	YD <--- NT	0.326	0.049	6.704	***	Accepted
H2a	NT <--- RR	-0.154	0.051	-3.010	0.003	Accepted
H2b	NT <--- DT	0.187	0.054	3.436	***	Accepted
H2c	NT <--- CQ	0.398	0.073	5.427	***	Accepted
H3	YD <--- KS	0.107	0.037	2.882	0.004	Accepted
H4	YD <--- CQ	0.208	0.062	3.349	***	Accepted
H5	HV <--- KS	0.315	0.052	6.029	***	Accepted
H6	HV <--- YD	0.639	0.069	9.232	***	Accepted

From the results and interpretations, the author tests the proposed research hypotheses. Specifically, hypothesis H1c is rejected, while the remaining hypotheses are accepted.

Table 9: Mediation Relationships.

Indirect Path	Unstandardized Estimate	Lower	Upper	P-Value	Standardized Estimate
HI --> TD --> YD	0.030	0.009	0.058	0.017	0.030*
HI --> TD --> YD --> HV	0.019	0.006	0.038	0.016	0.030*
SD --> TD --> YD	0.026	0.011	0.050	0.002	0.037**
SD --> TD --> YD --> HV	0.017	0.007	0.033	0.002	0.037**
RR --> TD --> YD	0.020	0.001	0.050	0.094	0.024†
RR --> TD --> YD --> HV	0.013	0.000	0.030	0.092	0.024†
RR --> NT --> YD	-0.050	-0.091	-0.019	0.009	-0.059**
RR --> NT --> YD --> HV	-0.032	-0.060	-0.013	0.008	-0.059**
KS --> TD --> YD	0.032	0.013	0.062	0.002	0.041**
KS --> TD --> YD --> HV	0.020	0.009	0.039	0.002	0.041**
KS --> YD --> HV	0.068	0.029	0.117	0.010	0.060**
DT --> NT --> YD	0.061	0.030	0.104	0.001	0.065***
DT --> NT --> YD --> HV	0.039	0.019	0.069	0.001	0.065***
CQ --> NT --> YD	0.130	0.085	0.188	0.001	0.114***
CQ --> NT --> YD --> HV	0.083	0.051	0.125	0.001	0.114***
CQ --> YD --> HV	0.133	0.054	0.228	0.004	0.080**
TD --> YD --> HV	0.179	0.112	0.269	0.001	0.101***
NT --> YD --> HV	0.208	0.148	0.289	0.001	0.159***

Using indirect effects in AMOS 24, the author obtained the results of the mediation relationships between variables as shown in the table above. Relationships with p-values less than 0.005 are significant. Thus, the results show that the YD variable plays a mediating role, affecting many relationships between other variables and the HV variable, including both first and second-order mediation roles. Additionally, the standardized regression coefficients of the relationships are positive, and both upper and lower limit values are positive. Therefore, the mediation relationships indicate that as the mediating variable increases, the relationship between independent and dependent variables also increases.

6.7. Moderation Analysis

By incorporating the model into AMOS 24, showing the relationship between YD and HV through the moderating variable DG, the author obtained the results of the moderation relationships between variables as shown in the table above. The results show that the relationships from DG to YD and from DG to HV are significant with p-value < 0.05, but the impact between INT (= YD*DG) and HV is not significant. Thus, DG does not play a moderating role in the relationship between YD and HV. The proposed hypothesis H7 is rejected.

Table 10: Moderation Analysis Results.

	Estimate	S.E.	C.R.	P
ZF_HV <--- ZF_YD	0.320	0.039	8.187	***
ZF_HV <--- ZF_DG	-0.467	0.037	-12.707	***
ZF_HV <--- INT	0.062	0.035	1.747	0.081

The research results show that most hypotheses are accepted, except for hypothesis H1c regarding the negative impact of perceived risk on consumer attitude. This indicates that attitude and purchase intention when watching livestream shopping are mainly influenced by perceived usefulness, ease of use, and perceived behavioral control. Additionally, consumer trust plays an important role in forming purchase intentions, where perceived risk negatively impacts trust, while perceived reputation of the streamer/business and subjective norms have a positive impact.

The regression analysis results show that relationships between variables in the research model are statistically significant, except for the relationship between perceived risk (RR) and trust (NT). The remaining relationships meet the set criteria with 95% confidence ($p < 0.05$). This indicates that the proposed theoretical model fits market data, providing insights into purchasing behavior when watching livestream shopping.

First, the results show that consumer attitude (TD) positively influences purchase intention (YD). This confirms that a positive attitude will encourage consumers to have purchase intentions when watching livestreams. Specifically, perceived usefulness (HI), ease of use (SD), and subjective norms (KS) positively impact consumer attitude. Notably, perceived risk (RR) also positively impacts attitude, which can be explained by consumers being accustomed to risks when shopping online and tending to accept them as part of the shopping process.

Second, trust (NT) significantly influences purchase intention. Trust is determined by perceived quality (CQ) and the perceived reputation of the streamer/business (DT). This shows that when consumers trust the product quality and the seller's reputation, they will have higher purchase intentions. Notably, perceived risk (RR)

negatively impacts trust, which is reasonable because high risk often reduces consumer trust.

Third, purchase intention (YD) is a crucial factor affecting actual purchase behavior (HV). The results show that when consumers have purchase intentions, their likelihood of making actual purchases is very high. Additionally, subjective norms (KS) positively impact purchase behavior, indicating the influence of the surrounding environment and others' opinions on individual purchasing decisions.

Table 11: Standardized Regression Coefficients.

	Estimate
NT ← CQ	0.313
NT ← DT	0.179
NT ← RR	-0.163
TD ← SD	0.162
TD ← HI	0.132
TD ← KS	0.179
TD ← RR	0.103
YD ← TD	0.231
YD ← NT	0.364
YD ← KS	0.137
YD ← CQ	0.182
HV ← YD	0.436
HV ← KS	0.278

Below are the standardized regression equations of the research model, showing the relationships between independent, mediating, and dependent variables:

Trust (NT) is determined by: $NT = 0.313 \times CQ + 0.179 \times DT - 0.163 \times RR$

Attitude (TD) is determined by: $TD = 0.162 \times SD + 0.132 \times HI + 0.179 \times KS + 0.103 \times RR$

Purchase Intention (YD) is determined by: $YD = 0.231 \times TD + 0.364 \times NT + 0.137 \times KS + 0.182 \times CQ$

Actual Purchase Behavior (HV) is determined by: $HV = 0.436 \times YD + 0.278 \times KS$

These equations show the impact relationships between variables in the research model and play an essential role in understanding the influence mechanism of each factor on purchasing behavior when watching livestream shopping. These results provide a solid basis for the proposed research hypotheses and help shape more effective marketing strategies in the context of online sales through livestreams.

7. CONCLUSION

7.1. Discussion

This study conducted a comprehensive analysis of purchasing behavior when watching online sales livestreams, focusing on the psychological and technological factors influencing consumers' purchasing decisions. The research results identified and verified key relationships between factors such as consumer attitudes, trust, perceived behavioral control, subjective norms, and purchase intentions. The main findings from the study can be summarized as follows:

Firstly, consumers' attitudes towards online sales livestreams positively affect purchase intentions. Specifically, perceptions of usefulness, ease of use, and perceived behavioral control contribute to a positive attitude towards purchasing while watching livestreams. Conversely, perceptions of risk do not significantly impact consumer attitudes, indicating that in the context of livestreams, this factor does not strongly influence purchasing decisions as expected.

Secondly, consumers' trust in livestreams also positively affects purchase intentions. Perceptions of risk, the reputation of the livestreamer, and subjective norms all play important roles in this trust, directly influencing consumers' purchasing decisions.

Thirdly, purchase intention is identified as a crucial factor leading to actual purchasing behavior. These results confirm that forming purchase intentions when watching livestreams can lead to actual shopping actions, highlighting the importance of factors influencing purchase intentions in driving consumer behavior.

Finally, the moderating variable does not have a clear influence in the research model, meaning that Online Consumer Reviews do not play a moderating role in the relationship between purchase intentions and purchasing behavior in the livestream context. This may be due to the unique nature of online sales via livestream, where consumers often make quick purchasing decisions and do not have enough time to thoroughly research product reviews from other consumers.

7.2. Contributions

7.2.1. Theoretical Contributions

This study contributes to consumer behavior theory by expanding the understanding of factors influencing shopping behavior in the livestream environment. The findings show that in the context of livestreams, psychological factors such as attitude, trust, and perceived behavioral control play more significant roles than risk perception. This adds to existing consumer behavior theories and provides new insights into the interaction

between psychological factors and shopping behavior in the online sales environment.

7.2.2. Practical Contributions

Practically, the study provides specific recommendations for businesses and livestreamers to enhance the effectiveness of their online sales strategies. Focusing on improving the quality of livestreams and enhancing perceptions of the platform's usefulness and ease of use can increase consumers' positive attitudes and trust. Simultaneously, businesses and livestreamers need to pay attention to building reputation and creating a positive shopping experience to increase consumer trust. These recommendations not only help businesses optimize their sales strategies but also contribute to increasing customer satisfaction and loyalty.

7.3. Recommendations

Based on the research results and analysis, several recommendations can be made to improve the effectiveness of online sales strategies through livestreams and enhance consumer satisfaction:

7.3.1. For Businesses and Livestreamers

Businesses and livestreamers play key roles in attracting and retaining customers through livestream sessions. They should focus on improving the quality of livestreams to enhance the perception of the platform's usefulness and ease of use. This can include providing detailed and clear product information, ensuring a smooth and easy user experience. Factors such as interactivity and image quality should also be improved to build trust and satisfaction among consumers. The following are specific suggestions from the author to improve the effectiveness of sales livestreams:

1. Enhance interactivity and user experience: Livestreamers should focus on directly interacting with the audience throughout the livestream, answering questions, and responding quickly to viewers' comments. This interaction not only strengthens the relationship between the seller and customers but also creates an engaging and close shopping environment.
2. Improve content and image quality: The quality of content and images in the livestream should be ensured at a high level. This includes using high-quality recording and sound equipment, thoroughly preparing livestream scripts, and selecting attractive and novel products to introduce to customers.
3. Train and enhance livestreamer skills: Businesses should invest in training livestreamers in communication, persuasion, and situation-handling skills. A professional and knowledgeable livestreamer will build trust and attract more customers.
4. Utilize technology and data: Use advanced technologies and data analysis to better understand consumer behavior and preferences. Businesses can apply analytical tools to monitor the effectiveness of each livestream, thereby adjusting strategies to optimize revenue.
5. Build brand and reputation: For livestreamers, building a positive and reputable personal brand image is crucial. This includes maintaining professional ethics, ensuring honesty and transparency during sales, and always prioritizing customer interests.
6. Encourage customer feedback and reviews: Businesses should encourage customers to leave feedback and reviews after purchasing. This feedback not only helps businesses improve services but also builds trust among potential customers.
7. Offer attractive promotions and discounts: Promotional programs, discounts, and gifts included with livestream purchases will stimulate interest and drive consumer purchasing behavior.

By applying these recommendations, businesses and livestreamers can enhance the effectiveness of their sales strategies through livestreams, thereby increasing customer satisfaction and loyalty.

7.3.2. For Consumers

Consumers also play an important role in promoting the development and improvement of the livestream sales model. Consumers should be more aware of the factors influencing their purchasing decisions when participating in livestream sessions. Carefully considering product information and reviews can help make more informed and reasonable purchasing decisions. The following are some recommendations for consumers to maximize the benefits of shopping through livestreams while contributing to improving the online shopping environment:

1. Research product and supplier information: Before making a purchase, consumers should thoroughly research the product and supplier. Read product descriptions carefully, review previous customer feedback, and assess the reputation of the livestreamer or business.
2. Ask questions and interact directly: Consumers should actively ask questions and request additional product information during the livestream. This not only helps them get a clearer view of the product but also provides an opportunity for suppliers to explain in more detail, leading to more accurate purchasing decisions.

3. Compare prices and offers: Before purchasing, consumers should compare prices and offers of the same product across multiple platforms or from different suppliers. This helps them choose the best option in terms of price and after-sales policies.
4. Provide feedback and reviews after purchase: After purchasing, consumers should leave feedback and reviews about the product and service of the supplier. This feedback not only helps suppliers improve services but also provides useful information for other consumers.
5. Protect personal rights: Consumers need to be aware of their rights and should not hesitate to file complaints or report issues related to product or service quality. This not only protects personal rights but also contributes to improving the quality of livestream sales services.
6. Utilize promotions reasonably: Consumers should take advantage of promotions and offers from livestream sessions reasonably, avoiding unnecessary purchases driven by marketing strategies.
7. Ensure personal information security: When shopping through livestreams, consumers need to pay attention to securing personal information and only provide necessary information to reputable suppliers with clear privacy policies.
8. Join shopping communities: Join online shopping communities, forums, or social media groups to share experiences and receive useful advice from other consumers.

By implementing these recommendations, consumers can ensure safe and effective shopping while contributing to building a civilized and reliable online shopping environment.

7.3.3. For Digital Platforms

Digital platforms play an important intermediary role in connecting businesses, livestreamers, and consumers. Digital platforms should improve support tools and interactive features to facilitate consumers' access to and evaluation of products when watching livestreams. Providing features that allow consumers to easily follow and interact with livestreams will help enhance their satisfaction and trust. To improve the shopping experience through livestreams and promote the sustainable development of this model, platforms should focus on several recommendations:

1. Enhance features and user experience: Platforms should continuously improve their interfaces and features to provide a smooth, easy-to-use experience for consumers. Features such as product search, filtering, sorting by needs, and reviewing and commenting should be optimized so users can easily find the information they need.
2. Technical support for livestreamers: To ensure the quality of livestream sessions, platforms should provide tools and technical support for livestreamers. This includes providing stable bandwidth, interaction management tools, and technical guidance to ensure high-quality livestream videos.
3. Protect consumer rights: Platforms should have clear and transparent policies to protect consumer rights, including return and exchange policies, personal information security, and complaint handling. This helps build trust and ensures consumers feel secure when shopping.
4. Strengthen quality management and control: Platforms should have measures to control and manage the quality of livestream content, ensuring products are sold as advertised and limiting fraudulent activities. This can include content moderation, requiring seller identity verification, and having mechanisms for reporting violations.
5. Encourage innovation and creativity: Platforms should encourage livestreamers and businesses to be creative in their approaches and interactions with customers. This can be through support programs, guidance on creating engaging content, and new interaction tools such as games, gifts, or special promotions during livestreams.
6. Create opportunities for connection and collaboration: Platforms should organize events, workshops, or training sessions to create opportunities for connection and collaboration between livestreamers, businesses, and industry experts. This helps share experiences, learn from each other, and promote the overall development of the livestream community.
7. Use data to improve services: Platforms should leverage user data to better understand customer needs and habits, thereby improving services and recommending suitable products. Data analysis also helps platforms develop more effective marketing strategies, personalize user experiences, and optimize the sales process.
8. Ensure safety and security: Safety and security are key factors in the online environment. Platforms should ensure their systems are protected against cybersecurity threats and have measures to protect users' personal information and transactions.

Through these improvements, digital platforms can enhance the shopping experience through livestreams, build consumer trust and satisfaction, and promote the sustainable development of this online sales model.

Thus, this research has successfully identified and tested the factors influencing consumers' purchasing behavior, including attitude, trust, risk perception, perceived behavioral control, and subjective norms. The structural equation modeling (SEM) analysis has demonstrated the suitability of the research model and the relationships between variables.

The research results provide important information for businesses, livestreamers, consumers, digital platforms, and government agencies, helping them optimize sales strategies, enhance consumer satisfaction, and promote sustainable development in the field of online sales via livestreams.

7.4. Limitations And Directions for Future Research

Despite the valuable contributions of this study, there are several limitations that need to be considered. Firstly, the study sample is limited to specific geographic areas and demographics, which may not fully represent the diverse consumer base in other regions or contexts. Secondly, data collection is mainly based on self-reported questionnaires, which may lead to subjective bias from respondents. Future research should focus on expanding the sample size and geographical scope to enhance the generalizability of the results. Additionally, employing diverse data collection methods, such as experimental designs or in-depth interviews, could provide more comprehensive insights into consumers' purchasing behavior when watching livestreams. Lastly, exploring the impact of emerging technologies and evolving consumer trends in the context of livestream sales would contribute to the continuous improvement and understanding of this dynamic field.

By addressing these limitations and building on the findings of this study, future research can further advance the knowledge of online consumer behavior and provide valuable guidance for optimizing the effectiveness of sales strategies through livestreams.

REFERENCES

- Ajzen, I. (1991). The Theory of Planned Behavior. *Organizational Behavior and Human Decision Processes*, 50(2), 179-211.
- Ajzen, I., & Fishbein, M. (1975). *Belief, Attitude, Intention, and Behavior: An Introduction to Theory and Research*. Reading, MA: Addison-Wesley.
- Barkhi, R., Belanger, F., & Hicks, J. (2008). A Model of the Determinants of Purchasing from Virtual Stores. *Journal of Organizational Computing and Electronic Commerce*, 18(1), 17-38.
- Bennett, R., Gabriel, H., & Marketing, F. (2001). Reputation, Trust and Supplier Commitment: The Case of Virtual Markets for Products and Services. *International Journal of Internet Marketing and Advertising*, 1(3), 218-237.
- Bhattacharjee, A., & Premkumar, G. (2004). Understanding Changes in Belief and Attitude Toward Information Technology Usage: A Theoretical Model and Longitudinal Test. *MIS Quarterly*, 28(2), 229-254.
- Brown, J. J., & Reingen, P. H. (1987). Social Ties and Word-of-Mouth Referral Behavior. *Journal of Consumer Research*, 14(3), 350-362.
- Chatterjee, P. (2001). Online Reviews: Do Consumers Use Them? *Advances in Consumer Research*, 28, 129-133.
- Chang, H. H., & Chen, S. W. (2008). The Impact of Online Store Environment Cues on Purchase Intention: Trust and Perceived Risk as a Mediator. *Online Information Review*, 32(6), 818-841.
- Chen, L.-D., & Tan, J. (2004). Technology Adaptation in E-commerce: Key Determinants of Virtual Stores Acceptance. *European Management Journal*, 22(1), 74-86.
- Chen, Y., & Xie, J. (2008). Online Consumer Review: Word-of-Mouth as a New Element of Marketing Communication Mix. *Management Science*, 54(3), 477-491.
- Davis, F. D. (1989). Perceived Usefulness, Perceived Ease of Use, and User Acceptance of Information Technology. *MIS Quarterly*, 13(3), 319-340.
- Fishbein, M., & Ajzen, I. (1975). *Belief, Attitude, Intention, and Behavior: An Introduction to Theory and Research*. Reading, MA: Addison-Wesley.
- Gefen, D. (2003). TAM or Just Plain Habit: A Look at Experienced Online Shoppers. *Journal of End User Computing*, 15(3), 1-13.
- Gefen, D., Karahanna, E., & Straub, D. W. (2003). Trust and TAM in Online Shopping: An Integrated Model. *MIS Quarterly*, 27(1), 51-90.
- Godes, D., & Mayzlin, D. (2004). Using Online Conversations to Study Word-of-Mouth Communication. *Marketing Science*, 23(4), 545-560.
- Hansen, T., Jensen, J. M., & Solgaard, H. S. (2004). Predicting Online Grocery Buying Intention: A Comparison of the Theory of Reasoned Action and the Theory of Planned Behavior. *International Journal of Information Management*, 24(6), 539-550.
- Jarvenpaa, S. L., Tractinsky, N., & Vitale, M. (2000). Consumer Trust in an Internet Store. *Information Technology and Management*, 1(1-2), 45-71.
- Lee, J., Park, D.-H., & Han, I. (2011). The Effect of Negative Online Consumer Reviews on Product Attitude: An Information Processing View. *Electronic Commerce Research and Applications*, 10(4), 341-352.
- Lin, H. F. (2007). The Impact of Website Quality Dimensions on Customer Satisfaction in the B2C E-commerce Context. *Total Quality Management & Business Excellence*, 18(4), 363-378.
- Mayer, R. C., Davis, J. H., & Schoorman, F. D. (1995). An Integrative Model of Organizational Trust. *Academy of Management Review*, 20(3), 709-734.
- Monsuwé, T. P. Y., Dellaert, B. G. C., & De Ruyter, K. (2004). What Drives Consumers to Shop Online? A Literature Review. *International Journal of Service Industry Management*, 15(1), 102-121.
- Park, C., & Lee, T. M. (2009). Information Direction, Website Reputation and eWOM Effect: A Moderating Role of Product Type. *Journal of Business Research*, 62(1), 61-67.
- Pavlou, P. A. (2003). Consumer Acceptance of Electronic Commerce: Integrating Trust and Risk with the Technology Acceptance Model. *International Journal of Electronic Commerce*, 7(3), 101-134.
- Püschel, J., Mazzon, J. A., & Hernandez, J. M. C. (2010). Mobile Banking: Proposition of an Integrated Adoption Intention Framework. *International Journal of Bank Marketing*, 28(5), 389-409.
- Shih, H. P. (2004). An Empirical Study on Predicting User Acceptance of E-shopping on the Web. *Information & Management*, 41(3), 351-368.
- Tan, Yuli. (2017). *The Business Model of Livestream E-commerce*. [Publisher information].
- Taylor, S., & Todd, P. A. (1995). Understanding Information Technology Usage: A Test of Competing Models. *Information Systems Research*, 6(2), 144-176.
- Teo, T. S. H., & Liu, J. (2007). Consumer Trust in E-commerce in the United States, Singapore and China. *Omega*, 35(1), 22-38.
- Vijayarath, L. R. (2002). Product Characteristics and Internet Shopping Intentions. *Internet Research*, 12(5), 411-426.
- Yoh, E., Damhorst, M. L., Sapp, S., & Laczniak, R. (2003). Consumer Adoption of the Internet: The Case of Apparel Shopping. *Psychology & Marketing*, 20(12), 1095-1118.
- Gefen, D., Karahanna, E., & Straub, D. W. (2003). Trust and TAM in Online Shopping: An Integrated Model. *MIS Quarterly*, 27(1), 51-90.
- David, G. (2003). TAM or Just Plain Habit: A Look at Experienced Online Shoppers. *Journal of End User Computing*, 15(3), 1-13.
- Pavlou, P. A., & Fygenson, M. (2006). Understanding and Predicting Electronic Commerce Adoption: An Extension of the Theory of Planned Behavior. *MIS Quarterly*, 30(1), 115-143.