

# The effect of employer attractiveness and CSR on recruiting potential Gen Y workers: Investigation of the tourism industry in Thailand

Supaporn Prasongthan

Kasetsart University, Faculty of Humanities, Bangkok Thailand; fhumsprr@ku.ac.th (S.P).

**Abstract.** The study aims to examine the dimension of employer attractiveness and CSR among potential Gen Y employees, explore how employer attractiveness and CSR influence their intention to pursuit job, and develop a structural model of intention to pursuit job among potential Gen Y job seekers in tourism sector. A total of two hundred Gen Y respondents participated in the study through convenience sampling method. Data was analyzed with multiple stages including EFA, CFA and SEM. Three underlying factors emerged for CSR support include society concern, employee concern, and customer and government concern. Additionally, the findings confirmed the theoretical concept of employer attractiveness consisting of five dimensions, development, social, interest, economic and application value. SEM analysis indicated a good fit with empirical data (CMIN/DF = 1.78, RMSEA = 0.06, CFI = 0.92, TLI = 0.91). The results revealed employer attractiveness and CSR support had positive influence on reputation and effect on Gen Y's intention to apply for job in the tourism industry. Employer attractiveness and CSR support can act as strategic tools. HR executives should develop a recruitment plan to draw Gen Y to the business, as well as enhance their industry-wide reputation. Fun-Fair-Flexible work environment should be implemented and communicated to target applicants. Digital strategy should be applied via online advertising and social media to communicate to both internal and external stakeholders.

**Keywords:** Corporate social responsibilities, Employer attractiveness, Intention to pursuit, Organizational reputation, Tourism industry, Thailand.

## 1 | BACKGROUND

Recruiting the most suitable candidate at the right time has become increasingly challenging for human resource managers in the twenty-first century due to globalization and the availability of access to the internet, which enable job searchers to research, evaluate, and compare information and benefits from different companies (Chowdhury, Moniruzzaman, Lipy, & Kang, 2024). Human resource practices are then essential in driving the organization as one of the key elements in creating a competitive advantage (Aloqaily, 2023; Sivertzen, Nilsen, & Olafsen, 2013). Particularly in the tourism industry, which involves labor-intensive tasks and depends on workers with skills, knowledge, and experience as a crucial instrument for providing services and establishing high standards. The recruitment process can be considered the initial step in acquiring an efficient and effective human capital (Soeling, Arsanti, & Indriati, 2022). As competition grows more intensely in recruiting qualified talents, companies must now differentiate themselves from the competition in order to attract skilled employees. A number of factors, including fair compensation, job characteristics, working conditions, opportunities for growth, welfare and benefits, positive company culture, corporate reputation and policies, etc., might influence the degree to which candidates apply for career in tourism and services businesses (Maxwell, Ogden, & Broadbridge, 2010; Soeling et al., 2022). Employer attractiveness has recently utilized as a recruiting tool to position the organization to potential employees as a desirable place to work. Additionally, the concept of Corporate Social Responsibilities (CSR) has been examined by a handful of literature and has caught the attention of businesses over decades since company activities have had direct and indirect impacts on society and environment. Accordingly, the business prioritizes the environment, ethics, corporate governance and employee well-being in all aspects of its operations. The studies of employer attractiveness and CSR were included not only for current employee but also for perspective employee. As a few research has investigated how CSR affects external stakeholders, particularly those who apply for positions. According to previous studies Chaihanchai and Anantachart (2024); Dosekova and Rheden (2018) and Hassan, Jambulingam, Alam, and Islam (2019) even though the workforce nowadays is more diverse with multigenerational employees from baby boomer to generation Z, generation Y (Gen Y) cohort is the world and Asia's largest population cohort and currently making up the greatest portion of the workforce within organizations. According to Alferjany and Alias (2020) Generation Y accounts for the largest group of workforces (35%). Understanding their values, beliefs, and expectations in the workplace can attract and retain talents which enhance organizational competitiveness. Based on previous studies Madden and Piboonrunroj (2016) and Pinzaru et al. (2016) there are likely to be cross cultural differences in the career expectations and employer attractiveness of Gen Y workers across countries. Further extended cross-nationally study need to be verified (Berthon, Ewing, & Hah, 2005; Madden & Piboonrunroj, 2016). Several studies examined how current employees perceived about organizational attractiveness and CSR (Buitek, Kaliyeva, Turginbayeva, Meldakhanova, & Shaikh, 2023; Styvén, Näppä, Mariani, & Natarajan, 2022). Few research, nonetheless, has investigated potential employees from a particular generation cohort. Given the aforementioned research gaps, this study aimed to answer following research questions; what aspects of the tourism business influence reputation and attract potential Gen Y workers? Drawing on the literature and the theory of employer attractiveness and CSR support, what are the key factors influencing the intention to apply for a job in tourism and service business organizations?

To deepen understanding, the researcher therefore aims to examine the dimension of employer attractiveness and CSR support among potential Gen Y employees, explore how employer attractiveness and CSR influence their intention to pursuit job, and develop a structural model of intention to pursuit job among potential Gen Y job seekers in tourism sector. The study's findings can provide insight information that help human resource executives in developing a recruitment plan to draw Gen Y to business and enhance organizational reputation in the marketplace. Implementing CSR practices can give tourism businesses a competitive edge in promoting and attracting young people into the workforce. Additionally, the theoretical contribution has been provided by confirming the assumption that employer attractiveness and employer support in CSR influence the intention to pursue job in the tourism sector. In addition to this introduction, there are four sections to this study. The concepts of employer attractiveness, CSR, reputation, and job pursuit intention are examined in the literature review before being applied to the formulation of hypotheses and the conceptual framework. The following section provides clarification on data analysis, questionnaire design, and sample methods. The results and discussion of

the study will then be discussed. Finally, the limitations and implications are examined.

## 2 | LITERATURE REVIEW AND THEORETICAL FRAMEWORK

### 2.1 | Social Identity Theory and Generation Y in the Workplace

Social identity theory (SIT) addresses the ways that social identities affect people's attitudes and behaviors based on their membership in social groups with similar norms, value and expectations (Tajfel & Turner, 1979). According to SIT, people often identify themselves with certain groups, or "in-groups", where they offer a sense of security, companionship and belonging. SIT can be used to explain generation cohort as social grouping where members identify with collective norms, values and memories from their generation (Van Rossem, 2019). The effects of generational identities have examined in various disciplines including psychology and cognitive sciences (Olckers & Booyesen, 2021; Weiss & Lang, 2009) media and communications (Kanani, Mousavi, & Beygzadeh, 2019; Laor & Galily, 2022) and business (Holian, 2015; Lyons & LeBlanc, 2019). In organizational context, SIT posits as a key success to human resource management as providing understanding about current employees' traits, ability, attributes and behavior who classify themselves in organization, work group, department and age cohort. Through immersion and interaction in organization groups, current employees gradually observe and share their interest, value, belief and norms with their members. Drawing on SIT, employees who identify more with the organization's practices perform better on the job as they are more enthusiastic to participate and support the organization achieve its objectives (Vu, 2022). Previous studies Banks, Kepes, Joshi, and Seers (2016); Highhouse, Thornbury, and Little (2007) and Wang and Chen (2022) expanded SIT into organizational attraction process as prospective employees frequently connect their self-concept to the organization they identify with.

According to previous studies Chaihanchai and Anantachart (2024); Dosekova and Rheden (2018) and Hassan et al. (2019) generation Y (Gen Y) cohort is the world and Asia's largest population cohort and currently making up the greatest portion of the workforce within organizations as the driving force of national economics and labor markets. The universal acceptable definition of Gen Y and the age ranges remain unclear; however, it is generally referred to be born between the early 1980s to early 2000s (Chamchan & Kittisuksathit, 2019). Unique sets of Gen Y characteristics and stereotypes were examined from several studies as digital natives who are self-confident, self-reliant, multi-tasking and place more value on autonomy, individuality, equality, and transparency (Dosekova & Rheden, 2018; Pinzaru et al., 2016). Prior studies Dhevabanchachai and Muangasame (2013); Dosekova and Rheden (2018); Goessling (2017); Maxwell et al. (2010) and Törn-Laapio and Ekonen (2021) has recognized Gen Y's values and expectations toward employment in the tourism industry including work-life balance, improve quality of life, career and personal development, career advancement, social relationship with supervisor, co-worker and customer, friendly and fun environment, good pay and benefit, fair employer and responsibility for society. On the other hand, some studies pointed out the negative side of Gen Y workforce including less disciplined, high levels of self-trust, high emotional fragility, low commitment to the organization resulting in low resistance to stress and high turnover rate (Chamchan & Kittisuksathit, 2019; Pinzaru et al., 2016). In this paper, the author has drawn upon the principle of SIT to unpack generation as a form of identity in the workplace, which will specifically encompassing perspective on prospective Gen Y employees in the tourism industry.

### 2.2 | Corporate Social Responsibility

As social and environmental problems including waste, pollution, climate change, and irresponsible human behavior become increasingly severe, public concern over sustainability issues has grown. The business nowadays has been expected to incorporate with responsible obligations toward social, economic, legal and ethical. Corporate social responsibility (CSR) is a revolutionary concept for businesses which integrated into business strategies and become part of the core business (Jamali & Mirshak, 2007; Rodriguez-Gomez, Arco-Castro, Lopez-Perez, & Rodríguez-Ariza, 2020). There is clearly no consensus on the definition of CSR since the term is based on many perspectives and is a notion that varies depending on the context (Turker, 2009A; Wan-Jan, 2006). This study defines CSR based on several studies James (2012); Licandro, Vázquez-Burguete, Ortigueira, and Correa (2023); Rodriguez-Gomez et al. (2020) and Turker (2009B) related to stakeholder's management theorists, as corporate responsible behaviors including economic, social, environmental, ethical and legal obligations that impact both internal and external stakeholders. CSR has been defined as a means of enhancing a company's reputation by promoting trust among stakeholders and employees (Esen, 2013; Tetrault Sirsly & Lvina, 2019; Wan-Jan, 2006). Moreover, empirical studies Ali, Satpathy, and Gupta (2024); Klimkiewicz and Oltra (2017); Presley, Presley, and Blum (2018) and Zhang, Cao, Zhang, Liu, and Li (2020) indicated the relationship between CSR and employer attractiveness which a good CSR can attract potential employees as well as current employees. Drawing from the empirical studies, the hypotheses were proposed as follows:

*H<sub>1</sub>: There is a significant relationship between CSR and employer attractiveness.*

*H<sub>3</sub>: There is a significant relationship between CSR and reputation.*

### 2.3 | Employer Brand and Employer Attractiveness

Ambler and Barrow (1996) proposed the notion of employer branding, which refers to a set of benefits offered by an organization in terms of function, economy, and psychology with the purpose of creating a desirable place to work. In human resource management, employer branding is used to facilitate an employee's identification with company. This identification can be used as an internal organizational identity for current employees as well as for external audiences to assess the company's employer value (Backhaus & Tikoo, 2004; Martin, Beaumont, Doig, & Pate, 2005). A positive image and well publicized employer brands can distinguish organizations from their competitors and can diminish employee acquisition costs, enhance employee relations, increase retention, and even can increase customer satisfaction and loyalty (Dosekova & Rheden, 2018; Ewing, Pitt, De Bussy, & Berthon, 2002; Pheunpha, 2021). According to Berthon et al. (2005) employer attractiveness is defined as the anticipated benefits that an ideal applicant believes they will obtain while working for a certain organization and it is strongly linked to employer branding. Thus, employer attractiveness specifically focuses on elements that attract potential employees of that organization. Job applicants' perceptions of employer attractiveness are formed from several factors including career advancement, compensation and benefit, job characteristic, working condition and work environment (Chamchan & Kittisuksathit, 2019; Maxwell et al., 2010; Soeling et al., 2022). Berthon et al. (2005) developed the well-known employer attractiveness scale (EmpAt), containing five dimensions that influence employer attractiveness. Interest value refers to perception of applicants toward exciting work environment that influences the use of creativity and innovation to produce products and services. Next, social value concerns relationships with others that build a sense of teamwork with fun and happy work environment. Economic value

represents the applicant's perception of the organization's financial and non-financial benefit provided i.e. above-average salary, compensation package and promotional opportunities. Fourthly, development value involves mostly satisfying psychological attributes that prospect employees attract in working in the organization, for example recognition, self-worth, confidence and career enhancement experience. Finally, application value indicates an opportunity for the future employee to apply their knowledge into practice and mentor others in a compassionate and customer-focused atmosphere. Several studies [Caputo, Molino, Cerato, and Cortese \(2023\)](#); [Eger, Mičik, Gangur, and Řehoř \(2019\)](#); [Silva and Dias \(2022\)](#) and [Sivertzen et al. \(2013\)](#) from different geographical locations applied EmpAt scale with different results based upon cross-cultural differences in employer attractiveness. Several studies scrutinized five dimensions of employer attractiveness as exogenous variable as well as endogenous variables. Considering the importance of employer attractiveness to induct interest of the potential candidates, this study proposed five dimensions of EmpAt scale as antecedent variables. Hence, the hypothesis and sub hypotheses were proposed as follows:

*H<sub>2</sub>: There is a significant relationship between Employer attractiveness and Industry reputation.*

## 2.4 | Reputation on Job Pursuit Intention

According to [Silva and Dias \(2022\)](#) and [Inversini \(2020\)](#) reputation is an intangible and valuable asset that requires to be developed and maintained. It develops throughout time from the perspectives of various stakeholders via advertising and social media. There are various levels at which reputation can be measured, including business, industry, and national. Corporate reputation is widely applied and extensively researched which reflects the organization's impression overtime from internal and external stakeholders. Whereas industry reputation is determined by the opinions held by stakeholders and the public regarding an industry. These judgments are based on assessments of the business's long-term impacts on the environment, society, and economy ([Winn, MacDonald, & Zietsma, 2008](#)). The tourism business has acknowledged the value of reputation as a vital resource for achieving competitive advantage ([Buhalis & Inversini, 2014](#); [Inversini, 2020](#)). Moreover, empirical studies [Sivertzen et al. \(2013\)](#) and [Soeling et al. \(2022\)](#) revealed that strong and positive reputation can affect a candidate's decision to apply for job. Building on above existing literature, this study purpose hypothesis as follows:

*H<sub>4</sub>: There is a significant relationship between reputation and job pursuit intention of potential GenY employees.*

The relationship between CSR, employer attractiveness, reputation and job pursuit intention were determined by the literature. Therefore, the following suggested theoretical framework is constructed (see [Figure 1](#)).

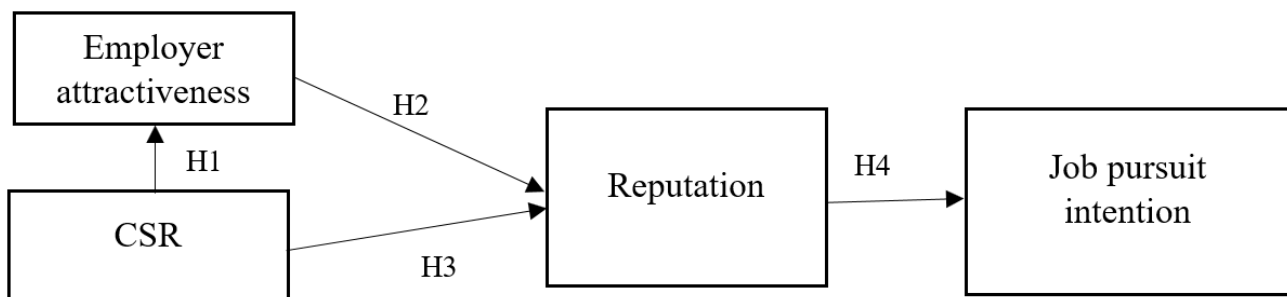

Figure 1: Proposed model.

## 3 | MATERIALS AND METHODS

This cross-sectional study was conducted in Thailand with a quantitative method to measure their perceptions of employer attractiveness, CSR support, reputation and their job pursuit intention.

### 3.1 | Sample Selection and Data Collection

The data was acquired from potential employees who are in Gen Y cohort, interested in working in the tourism sector and willing to participate in the research. Employing the convenience sampling approach, data was gathered from readily available and accessible samples that had been pre-screened with age and willingness to work in the tourism industry. The research project was approved by the Kasetsart University research ethics committee in Thailand prior to the data gathering process in order to comply with the three ethical principles including respect of persons, beneficence and justice. The online self-administration questionnaire was used to gather data between January and March of 2024 from a number of job-finding groups on social media platforms, including the Thai aviation career group and the hotels and services employment group. A total of 200 valid questionnaires out of the 224 were applied for data analysis. Research [Hoe \(2008\)](#); [Kline \(2016\)](#) and [Singh, Junnarkar, and Kaur \(2016\)](#) has shown that a minimum sample size of N=200 is necessary to provide sufficient statistical power for data analysis when applying Structural Equation Model (SEM) analysis.

### 3.2 | Survey Development

The survey questionnaire comprised of five main sections. [Berthon et al. \(2005\)](#) EmpAt scale was applied in the first section to quantify employer attractiveness. Five dimensions with 25-item scale were included: interest value (Int), social value (Soc), economic value (Eco), development value (Dev) and application value (App). The next session evaluated CSR perception on employer support with 18 items developed by previous studies ([Benraïss-Noailles, Herrbach, & Viot, 2021](#); [Hinson, Agbleze, & Kuada, 2018](#); [Turker, 2009B](#)). Five points-Likert scale were taken in sections 1 and 2 where 1 = not at all important and 5 = extremely important. Following with 4 questions about organizational reputation (Rep) which were adapted from [Sivertzen et al. \(2013\)](#) such as I have heard a lot of good things about working in tourism industry. Fourthly, the intention to pursuit job was investigated through 5 items adapted from the study of [Highhouse, Lievens, and Sinar \(2003\)](#) such as I would accept a job offer from a company in the tourism sector, I would recommend a friend to look for a job in the tourism sector. Section 3-4 were also measured on a five point-Likert scale where 1 = strongly disagree and 5 = strongly agree. In the last questionnaire session, respondents' age, gender, educational level, and preferred business to work such as hotel, food and beverage and transportation were gathered. An English-language questionnaire was translated into Thai

and then modified to fit the cultural setting of Thailand. Three academics who speak English well were closely examined for translations into Thai to reduce translation bias and the impacts of linguistic nuance.

### 3.3 | Data Analysis

The descriptive and multivariate analysis of the data was carried out in several stages, including structural equation modeling (SEM), exploratory factor analysis (EFA), confirmatory factor analysis (CFA), and correlation. The respondent's socio-demographic information was examined with a percentage score. The basic assumptions of SEM are then analyzed using multicollinearity and correlation tests. Subsequently, CSR support with eigenvalues more than 1 were categorized using principal component factor analysis with varimax rotation, which included items with factor loading greater than 0.6. The structural equation model was then performed using a two-stage method that included the measurement model and the structural model. In order to determine how the observed variables relate to the latent constructs and to evaluate the relationships between the observed variables and latent constructs, the measurement model is utilized. It is also essential for evaluating the validity and reliability of the measurement instruments by performing convergent and discriminant validity analysis. In the final phase, SEM analysis was carried out to ensure the developed model was consistent with empirical data. Examining the fit indices and parameter estimates is required in order to comprehend the SEM. Based on the guidelines suggested by Gefen, Straub, and Boudreau (2000) several goodness of fit indices, including absolute fit indices and incremental fit indices, will be exhibited. The chi-square/degree of freedom (CMIN/DF), root mean square error of approximation (RMSEA), comparative fit index (CFI), and Tukey-Lewis index (TLI) are the four criteria that are selected to signify acceptable fit index. The following model fit criterion cutoff values were suggested: CMIN/DF below 3, RMSEA below .08, CFI and TLI over 0.90 (Awang, 2012; Gefen et al., 2000). Analysis of the hypothesized relationships between the constructs was performed at the 5% significance level. The primary criteria for assessing a structural model in this study were the coefficient of determination ( $R^2$ ) and the significance levels of the path coefficients. According to Hair, Ringle, and Sarstedt (2011) value of  $R^2$  explains the model's explanatory power, the value over 0.75 is considered substantial, between 0.50-0.75 is moderate and 0.25-0.50 is weak. While investigating the path coefficient value, the value closer to  $+/-1$  would represent strong negative and positive relationship within the model and be significant at least at the 0.05 level (Hair et al., 2021).

## 4 | RESULTS

To examine the respondent profile, the descriptive statistical analysis was investigated. The results indicated that the majority of respondents were female (64 percent) who completed their bachelor's degree (52 percent) and were single (67 percent). The top three businesses that they would like to work within the foreseeable future are hotel and lodging (60.5 percent), transportation and airline (29 percent), and food and beverage (12.5 percent). Before conducting the multivariate analysis, multicollinearity and correlation tests were carried out. A correlation matrix was used to examine the relationship between the constructs. According to Yong and Pearce (2013) study, a low correlation coefficient ( $r < +/- .30$ ) should be eliminated since they demonstrate a lack of relationships. Consequently, four items with low correlation coefficient were removed from the investigation. Furthermore, with a tolerance value below 0.10 and a variance inflation factor (VIF) value above 10, each construct's VIF value and tolerance value showed no signs of multicollinearity. Therefore, the data was appropriate for factor analysis and the multicollinearity condition was not violated. In order to generate dimensions of CSR perception on employer support and to decrease the number of elements, EFA was explored. The sample was considered appropriate to conduct EFA according to the results of the Bartlett sphericity test and the Kaiser-Meyer-Olkin (KMO) analysis, with a KMO of 0.936 and a significant Bartlett's test of sphericity ( $p=0.000$ ). Three underlying factors, society concern (Soc), employee concern (Emp), and customer and government concern (Cus), emerged with eigenvalues more than 1 and factor loadings greater than 0.50. The estimated sum of the explained variance is 75.806%, indicating that the extraction is applicable. Factor 1, society concern (Soc), consists of 7 items representing employer target sustainable growth by taking part in environmental protection and improving society's quality of life. Factor 2, employee concern (Emp), is a combination of 4 items which demonstrate how the firm supports its employees' needs and wants by offering a flexible work schedule, supporting additional education, and delivering equitable decision-making. Factor 3, customer and government concern (Cus) is constructed with 3 items that exhibit the company's ethical obligation from both customer-centric and legal standpoint by offering comprehensive and accurate information about products and services as well as abiding by tax laws. These items emphasize the importance of customer satisfaction and compliance with legal requirements. After these factors were identified, the two-stage approach was implemented to construct the structural equation model of intention to pursuit job in tourism sector.

### 4.1 | Measurement Model

To assess the relationship between the constructs and the observed variable, the author constructed the overall measurement model as the first stage of SEM. The theorized constructs in a study were evaluated using the pooled confirmatory factor analysis (CFA) with both first and second order constructs in one measurement model. In second order CFA, employer attractiveness (Att) was drawn as the main construct and five sub-constructs (Dev, Soc, Int, Eco and App). While, CSR, Rep and Apply were performed as first order constructs. The validity and reliability of the measurement model were then assessed. A variety of convergent validity measurements were examined, including as factor loading, Cronbach's Alpha, average variance extracted (AVE), and construct reliability (CR) (Hair et al., 2011). Cronbach's Alpha values were shown to range from 0.82 to 0.94, exceeding Hair, Black, Babin, and Anderson (2006) recommended acceptable cut-off values of 0.70. High convergent validity is indicated by factor loading scores more than 0.60 (Hair et al., 2011). Additionally, average variance extracted (AVE) value were tested that the latent construct explains the indicator variance. Fornell and Larcker (1981) stated that an AVE value above 0.50, which indicates that the latent construct explains more than 50% of the indicator variation, is an acceptable degree of convergent validity. Table 1 illustrates the results of factor loading and AVE value which exceed the threshold (range from 0.84-.097). Therefore, it can be concluded that convergent validity was established. Composite reliabilities (CR) were also employed in the study to verify the internal consistency and stability of the scale. A minimum CR value of 0.70 is required, following Hair, Black, Babin, and Anderson (2010) the higher the value, the better the internal consistency. In this study, all constructs with CR value between 0.89-0.98 which can be assumed that all the items consistently measure their corresponding construct. Furthermore, evidence of discriminant validity is revealed using the conventional method of evaluating discriminant validity, as proposed by Fornell and Larcker (1981) where the square root of AVE should be higher than the correlation coefficient between latent variables. The result in Table 2 discriminant validity was considered sufficient because each construct evaluated unique and separate concepts. Additionally, the goodness of fit statistic was used to test the measurement model, and the results indicated that the model, with CMIN/DF = 1.85, RMSEA = 0.06, CFI = 0.92, and TLI = 0.90, had a good fit with the empirical data.

Therefore, it can be verified that the latent variable measurement model demonstrated discriminant validity, convergent validity, and internal consistency reliability, and that it could be assembled for the next step, SEM analysis.

**Table 1:** The CFA results for all main and sub constructs.

Constructs	Items	Loading	$\alpha$	CR	AVE
Employer attractiveness	Development value	0.98	0.93	0.98	0.97
	Social value	0.94			
	Interest value	0.99			
	Economic value	0.84			
	Application value	0.89			
Development value (Dev)	Dev1	0.68	0.82	0.89	0.86
	Dev3	0.77			
	Dev4	0.72			
	Dev5	0.77			
Social value (Soc)	Soc6	0.82	0.87	0.92	0.88
	Soc7	0.79			
	Soc8	0.70			
	Soc10	0.86			
Interest value (Int)	Int11	0.78	0.84	0.90	0.84
	Int12	0.80			
	Int13	0.71			
	Int14	0.69			
Economic value (Eco)	Eco15	0.89	0.88	0.91	0.89
	Eco16	0.79			
	Eco18	0.76			
	Eco19	0.76			
Application value (App)	App21	0.73	0.85	0.93	0.87
	App22	0.84			
	App23	0.87			
	App24	0.61			
CSR	Society concern	0.92	0.86	0.95	0.94
	Employee concern	0.91			
	Customer and government concern	0.81			
Society concern (Soc)	Csr1	0.78	0.94	0.96	0.90
	Csr2	0.84			
	Csr3	0.79			
	Csr4	0.87			
	Csr5	0.76			
	Csr7	0.76			
	Csr8	0.87			
Employee concern (Emp)	Csr10	0.91	0.92	0.96	0.93
	Csr11	0.87			
	Csr12	0.86			
	Csr13	0.86			
Customer and government concern (Cus)	Csr15	0.96	0.88	0.90	0.88
	Csr16	0.67			
	Csr17	0.73			
Reputation (Rep)	Rep1	0.75	0.85	0.91	0.88
	Rep2	0.86			
	Rep3	0.75			
	Rep4	0.72			
Intention to pursuit job (Apply)	Appy1	0.87	0.93	0.96	0.92
	Appy2	0.82			
	Appy3	0.87			
	Appy4	0.90			
	Appy5	0.82			

**Table 2:** Confidence intervals for the correlations for assessment of discriminant validity.

Construct	Att	CSR	Rep	Apply
<b>Att</b>	<b>0.98</b>			
<b>CSR</b>	0.769	<b>0.97</b>		
<b>Rep</b>	0.664	0.686	<b>0.94</b>	
<b>Apply</b>	0.572	0.561	0.756	<b>0.96</b>
<b>Note:</b> Values below the diagonal (Bold and italicized) represent square root of AVE values.				

## 4.2 | Structural Model

To demonstrate how the constructions are casually related, the structural model was evaluated. All four criteria meet the acceptable threshold levels suggested by Awang (2012) and Gefen et al. (2000) as evidenced by the goodness of fit statistics (CMIN/DF = 1.78, RMSEA = 0.06, CFI = 0.92, TLI = 0.91). These results suggest that the model is consistent with the empirical data. The coefficient of determination (R<sup>2</sup>) test and the path coefficients' significance levels were then used to test the hypotheses. For the purpose of discussing hypotheses testing, Figure 2 exhibits the standardized path coefficient and R<sup>2</sup> value. Hypothesis 1, the results of the study indicated a significant positive relationship ( $\beta = 0.843$ ,  $t = 7.90$ ,  $p < 0.001$ ). R<sup>2</sup> values of .71 demonstrate that employer support on CSR has a moderate impact on employer attractiveness. Upon examining the CSR dimensions in greater detail, the results revealed that Employee concern and Society concern were the two factors that had the greatest impact on CSR, with R<sup>2</sup> values of .87 and .85, respectively. It is possible to explain that the company focuses on employee needs and wants, along with a flexible work-life balance policy leading to attractiveness of the firm and acts as the primary attributes of Emp. Additionally, society concern (SOC), which emphasizes an organization's social duty to society and the next generation, was also the second major predictor of CSR perception on employer concern. The result thus supports the studies of Klimkiewicz and Oltra (2017) which highlight the work-life balance and ethics and CSR as the antecedent of employer attractiveness.

The second hypothesis was examined to test the relationship between employer attractiveness and reputation. The results indicated a significant positive relationship ( $\beta = 0.539$ ,  $t = 4.24$ ,  $p < 0.001$ ). Regarding employer attractiveness, the findings highlighted that all five dimensions had a high to moderate power of explanation and were positively significant. High explanatory power values were accorded to development value (Dev), interesting value (Int), social value (Soc), and application value (App) (R<sup>2</sup> = .99, .98, .94, and .81, respectively), while economic value has a moderate explanatory power (R<sup>2</sup> = .73). Statistical analysis revealed that gaining career enhancement experience and positive feeling about oneself are the main contributors to development value. For prospective Gen Y employees, creativity and an exciting work atmosphere are major attributes explaining interesting value. Good relationships with superiors, a joyful and enjoyable work atmosphere, acceptance and a sense of belonging are other attributes that contribute to an employer's attractiveness. It's noteworthy to observe that the economic value was the dimension that attracted the potential Gen Y employees the least, ranking lowest among employer attractiveness dimensions. This finding is in line with Klimkiewicz and Oltra (2017) and Reis, Braga, and Trullen (2017) who highlighted the significance of supervisor support, development opportunities and the work environment in enhancing an organization's attractiveness to prospective employees.

Next, the third hypothesis was tested. A significant positive relationship ( $\beta = 0.228$ ,  $t = 1.96$ ,  $p < 0.05$ ) has been found between CSR and reputation. As indicated by the R<sup>2</sup> value (.55), CSR perception of employer support along with employer attractiveness was presented as a modest level of explanation of industry wide reputation or in another word that the ability of model to predict organizational reputation is 55%. Regarding the contribution of reputation, the study's findings suggested that positive information about the companies has been shared with potential Gen Y employees, which could enhance their perception of the potential employee toward their reputation. The final hypothesis was examined, and the results indicate that reputation and the intention to apply for jobs have a significant positive relationship ( $\beta = 0.839$ ,  $t = 10.845$ ,  $p < 0.001$ ). The value of R<sup>2</sup> was determined to be .70, or 70%, which can possibly be used to indicate that company reputation contributes 70% to Gen Y potential employees' intention to pursue a job in the tourism sector. It could be explained that a company's positive reputation would encourage a candidate to apply for a job, accept an offer, and put in a great deal of effort at work. This finding aligns with Silva and Dias (2022) and Sivertzen et al. (2013) who underlined that employment intention increases with an organization's corporate reputation in the labor market. Thus, H<sub>1</sub>, H<sub>2</sub>, H<sub>3</sub> and H<sub>4</sub> were all supported. Hypotheses testing results were presented in Table 3.

**Table 3:** Hypotheses testing results.

Hypotheses	Path	Path coefficient	S.E.	C.R.	P value	Results
H <sub>1</sub>	Att < CSR	0.843	0.063	7.904	***	Supported
H <sub>2</sub>	Rep < Att	0.539	0.181	4.242	***	Supported
H <sub>3</sub>	Rep < CSR	0.228	0.097	1.966	0.049	Supported
H <sub>4</sub>	App < Rep	0.839	0.088	10.845	***	Supported

**Note:** \*\*\*p < 0.001.

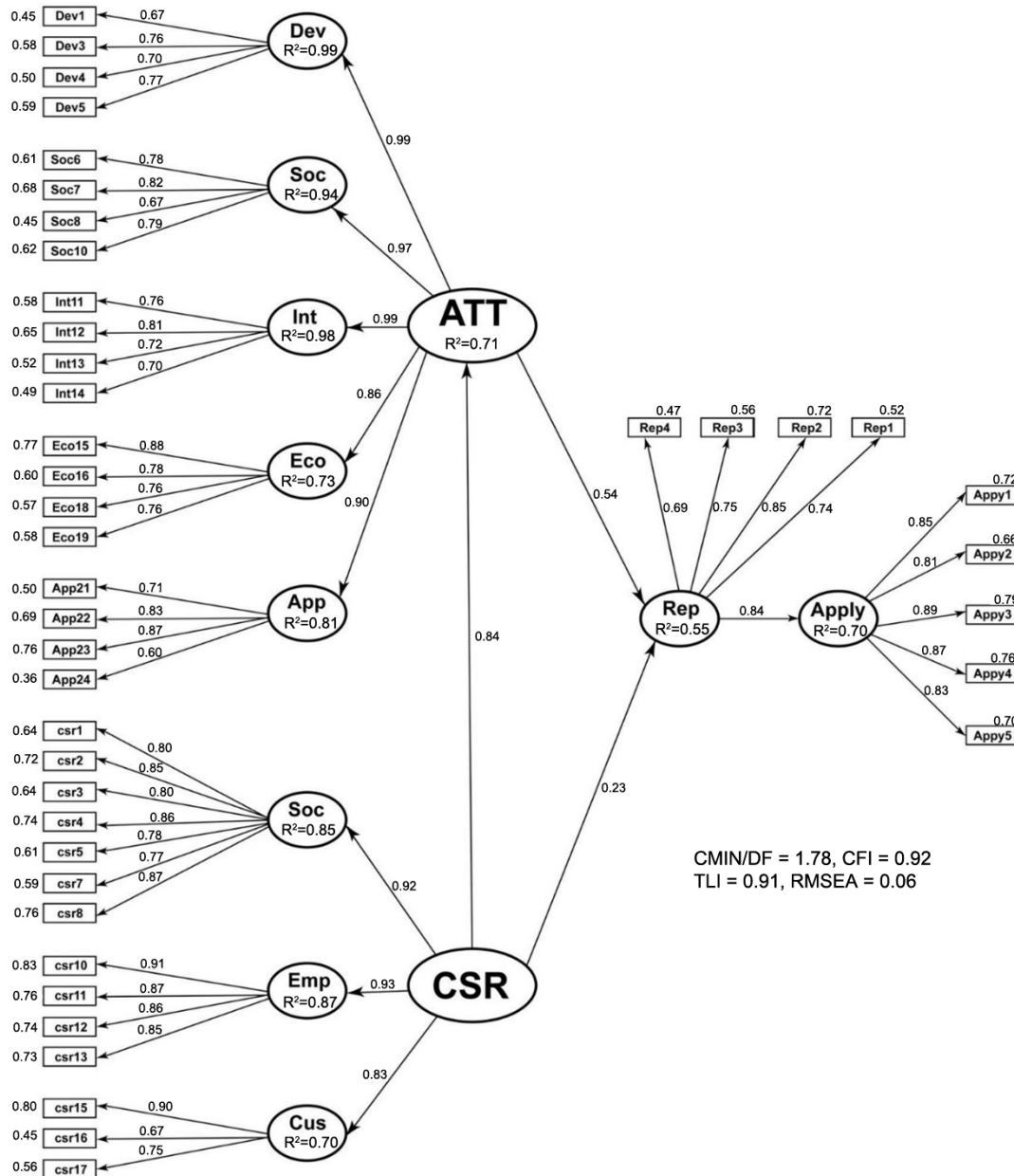

Figure 2: Structural model.

## 5 | CONCLUSION AND DISCUSSION

The objectives of this study were to examine the dimension of employer attractiveness and CSR among potential Gen Y employees, explore how employer attractiveness and CSR influence their intention to pursuit job in tourism sector. This research formulated four hypotheses testing with SEM analysis. The main findings of this study will be discussed.

Firstly, the five dimensions of employer attractiveness is confirmed accordingly to the most popular assessment tool by [Berthon et al. \(2005\)](#). Gen Y job seekers consider development value, interest value and social value when they think about working for their ideal employer in the tourism business. The attractiveness of gaining career-enhancement experience seems to be one of the top priorities to them which comply with [Maxwell et al. \(2010\)](#) and [Ognjanović \(2021\)](#) that discovered about Gen Y determination to success and achieve upward promotion, and potential employees in the hotel industry expect to have career advancement and employee training and development. Being recognized and good relationships with superiors were also important for Gen Y target job applicants as they are looking for the instant and frequent positive feedback and gratification from management ([Pinzaru et al., 2016](#)). Additionally, since Gen Y cohort members considered to be in digital technology and access to internet world, as that they tend to attract with the organization and or industry that make use of their creativity ideas. According to [Styvén et al. \(2022\)](#) findings that innovative and creativity are the most influential factors for employees in the hospitality and tourism field. Friendly work environment with fun, happy and exciting atmosphere was also striking to Gen Y job applicants which align with the findings of [Dhevabanchachai and Muangasame \(2013\)](#) that currents Thai employees in lodging business made some comments toward things they could do to enhance the fun environment such a sing a song, eat at work, or even dance doing working time. Previous research in Romania ([Pinzaru et al., 2016](#)) and Australia ([Berthon et al., 2005](#)) as well stated about nonconformist environment without strict rules and traditional work motivated Gen Y workers. Surprisingly, the economic value was the least attractive dimension to potential Gen Y employees. In accordance with [Goessling \(2017\)](#) and [Silva and Dias \(2022\)](#) money isn't the source of motivation that it once was. Work-life balance, flexibility of schedules, freedom of expression, collaborative environment, and alignment of employees' values with the organization have recently increased importance.

Secondly, the study's findings support the theoretical aspects of EmpAt scales that have positive effects on reputation and, thus, raise Gen Y's

preference to seek employment in the tourism industry. Linking this finding with previous studies [Nugroho \(2018\)](#); [Silva and Dias \(2022\)](#); [Sivertzen et al. \(2013\)](#) and [Soeling et al. \(2022\)](#) the potential employees who perceived employer attractiveness will gain a more positive reputation toward working in the tourism industry. This finding adds to the relevance of social identity theory that people often identify themselves with certain groups where they belong. The top three values that organizations need to focus on increase their attractiveness include development value, interest value and social value as explained before. Third, the study's findings demonstrated how important CSR is which requires businesses to conduct their operations in an ethical, accountable and responsible manner. Three emerging dimensions were revealed defining into different stakeholder groups including social, employee, customer and government. CSR support on employees was the most significant predictor with the highest R2 value. As Gen Y cohort members or Generation Me as synonym place more value centered on their own needs and want things to develop on their desire ([Pinzaru et al., 2016](#)). The concerned with their needs and wants is the highest mean score, followed by work life balance and fair decision. A study conducted by [Goessling \(2017\)](#) revealed that Gen Y demand more on schedule flexibility and work life balance and want to work for companies that have a reputation of operating with fairness and integrity. CSR to social concern is also important to Gen Y as they are concerned with social environment and sustainable growth which will create a better life for future generations. As mentioned by [Zainee and Puteh \(2020\)](#) that Gen Y believes that their employers should have responsibilities toward the society and the environment. CSR to customers and government appeared to be the weakest explanatory power. A possible explanation can be that the tourism industry is a people-oriented business which always depends on their satisfaction, thus potential employees are also aware of the value of customers. There is sufficient evidence to confirm that CSR plays a key role for candidates' perception of employer attractiveness. If Gen Y perceives the company's CSR activities as positive, this enhances the employer attractiveness which in turn develop anticipated sense of pride in joining the organization and establishes a value fit between Gen Y candidates and organization ([Klimkiewicz & Oltra, 2017](#); [Rank & Contreras, 2021](#)). Additionally, the empirical evidence supports the extending body of knowledge on the antecedent of employer attractiveness. According to [Kumar \(2023\)](#) job applicants' perceptions of employer attractiveness are formed from several sources including company portals, job advertisements, social media posts and employees' opinions. This current study shreds the light and confirms that CSR creates a good reputation for tourism business as well as becoming one of key driving employer attractiveness to potential employees ([Dassler, Khapova, Lysova, & Korotov, 2022](#); [Presley et al., 2018](#); [Turker, 2009A](#)).

Lastly, this study emphasized employer attractiveness and CSR as the antecedent of reputation which effect to intention to apply for jobs in the Tourism sector. According to social identity theory, individuals obtain emotional significance when they feel a sense of unity with the group they identify with ([Wang & Chen, 2022](#)). Linking this finding to SIT literature, social identification seems to have a powerful effect on how job applicants perceive employer attractiveness and employer support toward CSR activities. It can be proposed that if Gen Y potential employees perceive the organization as being a socially responsible firm, it can positively affect their identification to be suitable with the organization. Furthermore, the empirical data shows that the intention to apply for jobs increases with the tourism industry's reputation. Likewise, [Silva and Dias \(2022\)](#) demonstrated positive relationship between organizational reputation and intentions to apply for job.

## 5.1 | Implications and Limitations

A novel contribution of this study confirms employer attractiveness and CSR influence Gen Y job seekers' intention to pursuit job in the tourism industry. The results confirm the notion of employer attractiveness by [Berthon et al. \(2005\)](#) and employer support in CSR by [Turker \(2009A\)](#) which positive effect to intention to apply for job. The main findings of this study reveal several attributes that make the company a desirable place to work and influence intention to apply for job including gaining career-enhancement experience, being recognized, good relationship with superiors, that make use of their creative ideas, friendly work environment, work life balance and fair decision. HR executives should develop a strategy plan for attracting and recruiting Gen Y workers to the field, as well as empowering their industry-wide reputation. Employer attractiveness can act as a strategic tool because it allows attracting the top candidates and promoting their reputation in the market ([Silva & Dias, 2022](#)). In this way, fostering 3F work environment; Fun-Fair-Flexible, should be implemented and communicated to target applicants. Additionally, career development plans should be presented to clarify the chance of elevating career through goal setting, career path, and training and development programs. Even though CSR is now integrated into business strategies and has become part of the core business ([Jamali & Mirshak, 2007](#); [Rodriguez-Gomez et al., 2020](#)). The organizations need to enhance CSR communication through several channels; traditional media, digital media and report, to increase awareness about social and environment issues, as well as create favorable organization images. Maintaining a positive reputation requires both strong relationship-building and efficient communication ([Chondrogiannis et al., 2019](#)). In this sense, sustainability reports have now an essential part of business which can communicate with both internal and external stakeholders. Digital strategies could be applied such as online advertising and social media to communicate to both internal and external stakeholders. Online employer branding campaigns on social media platform could be established, enabling current staff members to share their experiences working for the company, their goals and their advancement which in an effort to draw in new hires. Therefore, businesses who may develop a reputation for being excellent places to work will have competitive advantage in the future marketplace ([Goessling, 2017](#)).

Several limitations are subject to this study. Firstly, nevertheless the respondents were potential employees in the tourism industry, it is possible that their backgrounds and levels of industry knowledge differed. Additionally, the tourism industry comprises of several businesses including lodging, food and beverage, transportation, souvenir, entertainment and etc. The future research should concentrate on each business to obtain insightful data. Secondly, the respondents are only Thai Generation Y cohort, the generalizability of the findings can be applied only in Thailand. The multi-generational and multi-cultural study need to be explored in the future in order to compare their perception toward employer attractiveness, CSR support and intention to apply for job in tourism industry. Thirdly, through the means of an online self-administrative questionnaire, the respondent may provide incorrect or insufficient information throughout the data collection procedure. Lastly, this study employs the cross-sectional study methodology. To find any changes in perception over time, a longitudinal study would be beneficial to investigate. Repeated surveys comparing prospective and current employees may yield more detailed results and reveal shifts in their attitudes and perceptions over time.

### Institutional Review Board Statement:

The Ethical Committee of the Kasetsart University Research Ethics Committee, Thailand has granted approval for this study on 26, December 2023 (Ref.No.COE66/133).

## REFERENCES

Alferjany, M., & Alias, R. B. (2020). Generational differences in values and attitudes within workplace. *Psychology and Education Journal*, 57(9),

1496-1503.

- Ali, E., Satpathy, B., & Gupta, D. R. (2024). Examining the effects of CSR on organizational attractiveness: Perception study of job seekers in India. *Journal of Global Responsibility*, 15(1), 19-52. <https://doi.org/10.1108/JGR-11-2021-0098>
- Aloqaily, A. (2023). The role of HRM practices on the talent management: Evidence from Jordanian commercial banks. *ABAC Journal*, 43(3), 180-196. <https://doi.org/10.59865/abacj.2023.37>
- Ambler, T., & Barrow, S. (1996). The employer brand. *Journal of Brand Management*, 4(3), 185-206. <https://doi.org/10.1057/bm.1996.42>
- Awang, Z. (2012). *A handbook on SEM. Structural equation modeling: SEM using AMOS graphic* (5th ed.). Kota Baru: Universiti Teknologi Mara Kelantan.
- Backhaus, K., & Tikoo, S. (2004). Conceptualizing and researching employer branding. *Career Development International*, 9(5), 501-517. <https://doi.org/10.1108/13620430410550754>
- Banks, G. C., Kepes, S., Joshi, M., & Seers, A. (2016). Social identity and applicant attraction: Exploring the role of multiple levels of self. *Journal of Organizational Behavior*, 37(3), 326-345. <https://doi.org/10.1002/job.2043>
- Benraïss-Noailles, L., Herrbach, O., & Viot, C. (2021). The impact of CSR perceptions on employer attractiveness: An empirical study. *Question (s) de Management*, 32(2), 15-24. <https://doi.org/10.3917/qdm.212.0015>
- Berthon, P., Ewing, M., & Hah, L. L. (2005). Captivating company: Dimensions of attractiveness in employer branding. *International Journal of Advertising*, 24(2), 151-172. <https://doi.org/10.1080/02650487.2005.11072912>
- Buhalis, D., & Inversini, A. (2014). Tourism branding and reputation in the age of social media in tourism management, marketing and development: The importance of networks and ICTs. In (pp. 15-40). New York: Palgrave, Macmillan.
- Buitek, E. K., Kaliyeva, S. A., Turginbayeva, A. N., Meldakhanova, M. K., & Shaikh, A. A. (2023). How much does an employer's attractiveness matter to youth employment? Evidence from a developing country. *Asia-Pacific Journal of Business Administration*. <https://doi.org/10.1108/apjba-02-2023-0086>
- Caputo, A., Molino, M., Cerato, B., & Cortese, C. G. (2023). Employer attractiveness: Two instruments to measure employer branding and reputation. *SAGE Open*, 13(3), 21582440231192188. <https://doi.org/10.1177/21582440231192188>
- Chaihanchanchai, P., & Anantachart, S. (2024). Urban living with style: An exploratory survey of Bangkok generation Y's lifestyle. *Journal of Population and Social Studies*, 32, 36-55. <https://doi.org/10.25133/JPSSv322024.003>
- Chamchan, C., & Kittisuksathit, S. (2019). Generation Y employees in Thai workplaces: What make them stay or leave. *Asia-Pacific Social Science Review*, 19(1), 49-65. <https://doi.org/10.59588/2350-8329.1201>
- Chondrogiannis, M., Katsios, S., Belias, D., Velissariou, E., Papadimopoulos, I., & Koustelios, A. (2019). *Reputation management in the tourism industry*. In Papathanassis, A., Katsios, S., Dinu, N.R. (Eds), *Yellow tourism tourism, hospitality & event management*. Cham: Springer.
- Chowdhury, M. S., Moniruzzaman, H., Lipy, N. S., & Kang, D.-s. (2024). Modeling corporate social responsibility and organizational attractiveness: The underlying mechanism of organizational trust. *South Asian Journal of Business Studies*, 13(4), 545-562. <https://doi.org/10.1108/SAJBS-05-2021-0187>
- Dassler, A., Khapova, S. N., Lysova, E. I., & Korotov, K. (2022). Employer attractiveness from an employee perspective: A systematic literature review. *Frontiers in Psychology*, 13, 858217. <https://doi.org/10.3389/fpsyg.2022.858217>
- Dhevabanchachai, N.-T., & Muangasame, K. (2013). The preferred work paradigm for generation y in the hotel industry: A case study of the international tourism and hospitality international programme, Thailand. *International Education Studies*, 6(10), 27-38. <https://doi.org/10.5539/ies.v6n10p27>
- Dosekova, L., & Rheden, E. (2018). *Employer branding amongst Millennials in the hospitality industry*. Master Thesis, Lund University, Lund, Sweden.
- Eger, L., Mičik, M., Gangur, M., & Řehoř, P. (2019). Employer branding: Exploring attractiveness dimensions in a multicultural context. *Technological and Economic Development of Economy*, 25(3), 519-541. <https://doi.org/10.3846/tede.2019.9387>
- Esen, E. (2013). The influence of corporate social responsibility (CSR) activities on building corporate reputation. In Gonzalez-perez, M.A. and Leonard, L. (Eds.), *International business, sustainability and corporate social responsibility advances in sustainability and environmental justice*. In (pp. 133-150). Leeds: Emerald Group Publishing Limited.
- Ewing, M. T., Pitt, L. F., De Bussy, N. M., & Berthon, P. (2002). Employment branding in the knowledge economy. *International Journal of Advertising*, 21(1), 3-22. <https://doi.org/10.1080/02650487.2002.11104914>
- Fornell, C., & Larcker, D. F. (1981). Evaluating structural equation models with unobservable variables and measurement error. *Journal of Marketing Research*, 18(1), 39-50. <http://dx.doi.org/10.2307/3151312>
- Gefen, D., Straub, D., & Boudreau, M.-C. (2000). Structural equation modeling and regression: Guidelines for research practice. *Communications of the Association for Information Systems*, 4(1), 2-77. <https://doi.org/10.17705/1cais.00407>
- Goessling, M. (2017). *Attraction and retention of generations X, Y and Z in the workplace integrated studies 66*. Retrieved from <https://digitalcommons.murraystate.edu/bis437/66>
- Hair, J., Black, W., Babin, B., & Anderson, R. (2006). *Multivariate data analysis* (6th ed.). Upper Saddle River, NJ: Pearson Prentice Hall.
- Hair, J. F., Black, W., Babin, B., & Anderson, R. (2010). *Multivariate data analysis* (7th ed.). New York: Pearson.
- Hair, J. F., Hult, G. T. M., Ringle, C. M., Sarstedt, M., Danks, N. P., & Ray, S. (2021). *Partial least squares structural equation modeling (PLS-SEM) using R*. Cham: Springer.
- Hair, J. F., Ringle, C. M., & Sarstedt, M. (2011). PLS-SEM: Indeed a silver bullet. *Journal of Marketing Theory and Practice*, 19(2), 139-152. <https://doi.org/10.2753/MTP1069-6679190202>
- Hassan, M., Jambulingam, M., Alam, M. N., & Islam, S. (2019). Redesigning the retention strategy against the emerging turnover of generation Y: Revisiting the long-standing problems from 20Th to 21St century. *International Journal of Entrepreneurship*, 23(2), 1-16.
- Highhouse, S., Lievens, F., & Sinar, E. F. (2003). Measuring attraction to organizations. *Educational and Psychological Measurement*, 63(6), 986-1001. <https://doi.org/10.1177/0013164403258403>
- Highhouse, S., Thornbury, E. E., & Little, I. S. (2007). Social-identity functions of attraction to organizations. *Organizational Behavior and Human Decision Processes*, 103(1), 134-146. <https://doi.org/10.1016/j.obhdp.2006.01.001>
- Hinson, R., Agbleze, S., & Kuada, J. E. (2018). Corporate social responsibility and employer attractiveness: Perspectives of prospective jobseekers in Ghana. *African Journal of Business Ethics*, 12(2), 1-17. <https://doi.org/10.15249/12-2-190>

- Hoe, S. L. (2008). Issues and procedures in adopting structural equation modelling technique. *Journal of Quantitative Methods*, 3(1), 76-83.
- Holian, R. (2015). Work, career, age and life-stage: Assumptions and preferences of a multigenerational workforce. *Labour & Industry: A Journal of the Social and Economic Relations of Work*, 25(4), 278-292. <https://doi.org/10.1080/10301763.2015.1083366>
- Inversini, A. (2020). Reputation in travel and tourism: A perspective article. *Tourism Review*, 75(1), 310-313. <https://doi.org/10.1108/TR-04-2019-0127>
- Jamali, D., & Mirshak, R. (2007). Corporate social responsibility (CSR): Theory and practice in a developing country context. *Journal of Business Ethics*, 72, 243-262. <https://doi.org/10.1007/s10551-006-9168-4>
- James, L. (2012). Sustainable corporate social responsibility-An analysis of 50 definitions for a period of 2000-2011. *ZENITH International Journal of Multidisciplinary Research*, 2(10), 169-193.
- Kanani, M. A., Mousavi, S. H., & Beygzadeh, Z. (2019). Media as a generational object: Investigating the role of media consumption on generational identity. *Strategic Research on Social Problems*, 8(3), 35-56. <https://doi.org/10.22108/srsp.2020.121075.1491>
- Klimkiewicz, K., & Oltra, V. (2017). Does CSR enhance employer attractiveness? The role of millennial job seekers' attitudes. *Corporate Social Responsibility and Environmental Management*, 24(5), 449-463. <https://doi.org/10.1002/csr.1419>
- Kline, R. B. (2016). *Principles and practice of structural equation modeling* (4th ed.). New York: Guilford Press.
- Kumar, P. (2023). The pulse of gen y in India: An exploratory study on dimensions of employer attractiveness. *Indian Journal of Industrial Relations*, 58(4), 627-643.
- Laor, T., & Galily, Y. (2022). Who'S clicking on on-demand? media consumption patterns of generations Y & Z. *Technology in Society*, 70, 102016. <https://doi.org/10.1016/j.techsoc.2022.102016>
- Licandro, O., Vázquez-Burguete, J. L., Ortigueira, L., & Correa, P. (2023). Definition of corporate social responsibility as a management philosophy oriented towards the management of externalities: Proposal and argumentation. *Sustainability*, 15(13), 10722. <https://doi.org/10.3390/su151310722>
- Lyons, S. T., & LeBlanc, J. E. (2019). Generational identity in the workplace: Toward understanding and empathy. In R. K. Burke, & A. M. Richardsen (Eds.), *Creating Psychologically Healthy Workplaces*. In (pp. 270-291). Northampton: Edward Elgar Publishing.
- Madden, R., & Piboonrunroj, P. (2016). *Gen Y in the workplace: A perspective from Thailand*. Kuala Lumpur: Asian Institute of Finance.
- Martin, G., Beaumont, P., Doig, R., & Pate, J. (2005). Branding: A new performance discourse for HR? *European Management Journal*, 23(1), 76-88. <https://doi.org/10.1016/j.emj.2004.12.011>
- Maxwell, G. A., Ogden, S. M., & Broadbridge, A. (2010). Generation Y's career expectations and aspirations: Engagement in the hospitality industry. *Journal of Hospitality and Tourism Management*, 17(1), 53-61. <https://doi.org/10.1375/jhtm.17.1.53>
- Nugroho, A. H. (2018). The influence of employer attractiveness, corporate reputation and the use of social media towards intention to apply for a job. *International Journal of Management, Accounting & Economics*, 5(7), 553-565.
- Ognjanović, J. (2021). Preferred attributes of employer brand attractiveness among potential employees in the hotel industry. *The European Journal of Applied Economics*, 18(2), 146-160. <https://doi.org/10.5937/ejae18-32929>
- Olckers, C., & Booyen, C. (2021). Generational differences in psychological ownership. *SA Journal of Industrial Psychology*, 47(1), 1-13. <https://dx.doi.org/10.4102/sajip.v47i0.1844>
- Pheunpha, P. (2021). The influence of corporate image and marketing mix on consumer motives: An empirical study of mk restaurants. *ABAC Journal*, 41(4), 43-66. <https://doi.org/10.14456/abacj.2021.3>
- Pinzaru, F., Vătămanescu, E.-M., Mitan, A., SĂVULESCU, R., Vițelar, A., Noaghea, C., & BĂLAN, M. (2016). Millennials at work: Investigating the specificity of generation Y versus other generations. *Management Dynamics in the Knowledge Economy*, 4(2), 173-192.
- Presley, A., Presley, T., & Blum, M. (2018). Sustainability and company attractiveness: A study of American college students entering the job market. *Sustainability Accounting, Management and Policy Journal*, 9(4), 470-489. <https://doi.org/10.1108/SAMPJ-03-2017-0032>
- Rank, S., & Contreras, F. (2021). Do millennials pay attention to corporate social responsibility in comparison to previous generations? Are they motivated to lead in times of transformation? A qualitative review of generations, CSR and work motivation. *International Journal of Corporate Social Responsibility*, 6(4), 1-13. <https://doi.org/10.1186/s40991-020-00058-y>
- Reis, G. G., Braga, B. M., & Trullen, J. (2017). Workplace authenticity as an attribute of employer attractiveness. *Personnel Review*, 46(8), 1962-1976. <https://doi.org/10.1108/PR-07-2016-0156>
- Rodriguez-Gomez, S., Arco-Castro, M. L., Lopez-Perez, M. V., & Rodríguez-Ariza, L. (2020). Where does CSR come from and where does it go? A review of the state of the art. *Administrative Sciences*, 10(3), 60. <https://doi.org/10.3390/admsci10030060>
- Silva, A. J., & Dias, H. (2022). The relationship between employer branding, corporate reputation and intention to apply to a job offer. *International Journal of Organizational Analysis*, 31(8), 1-16. <https://doi.org/10.1108/IJOA-01-2022-3129>
- Singh, K., Junnarkar, M., & Kaur, J. (2016). *Measures of positive psychology, development and validation*. Berlin: Springer.
- Sivertzen, A.-M., Nilsen, E. R., & Olafsen, A. H. (2013). Employer branding: Employer attractiveness and the use of social media. *Journal of Product & Brand Management*, 22(7), 473-483. <https://doi.org/10.22555/pbr.v24i3.691>
- Soeling, P. D., Arsanti, S. D. A., & Indriati, F. (2022). Organizational reputation: Does it mediate the effect of employer brand attractiveness on intention to apply in Indonesia? *Heliyon*, 8(4), e09208. <https://doi.org/10.1016/j.heliyon.2022.e09208>
- Styvén, M. E., Näppä, A., Mariani, M., & Nataraajan, R. (2022). Employee perceptions of employers' creativity and innovation: Implications for employer attractiveness and branding in tourism and hospitality. *Journal of Business Research*, 141, 290-298. <https://doi.org/10.1016/j.jbusres.2021.12.038>
- Tajfel, H., & Turner, J. C. (1979). An integrative theory of intergroup conflict. In W. G. Austin, & S. Worchel (Eds.), *The social psychology of intergroup relations*. In (pp. 33-47). Monterey, CA: Brooks/Cole.
- Tetrault Sirsly, C.-A., & Lvina, E. (2019). From doing good to looking even better: The dynamics of CSR and reputation. *Business & Society*, 58(6), 1234-1266. <https://doi.org/10.1177/0007650315627996>
- Törn-Laapio, A., & Ekonen, M. (2021). *Meaning of work across different generations of tourism and hospitality employees*. Paper presented at the The 4th International Conference on Tourism Research ICTR2021 (pp.530-537).
- Turker, D. (2009A). How corporate social responsibility influences organizational commitment. *Journal of Business Ethics*, 89, 189-204. <https://doi.org/10.1007/s10551-008-9993-8>
- Turker, D. (2009B). Measuring corporate social responsibility: A scale development study. *Journal of Business Ethics*, 85, 411-427.

<https://doi.org/10.1007/s10551-008-9780-6>

- Van Rossem, A. H. (2019). Generations as social categories: An exploratory cognitive study of generational identity and generational stereotypes in a multigenerational workforce. *Journal of Organizational Behavior*, 40(4), 434-455. <https://doi.org/10.1002/job.2341>
- Vu, T.-V. (2022). Perceived socially responsible HRM, employee organizational identification, and job performance: The moderating effect of perceived organizational response to a global crisis. *Heliyon*, 8(11), e11563. <https://doi.org/10.1016/j.heliyon.2022.e11563>
- Wan-Jan, W. S. (2006). Defining corporate social responsibility. *Journal of Public Affairs*, 6(3-4), 176 -184. <https://doi.org/10.1002/pa.227>
- Wang, H.-y., & Chen, Z.-X. (2022). Corporate social responsibility and job applicant attraction: A moderated-mediation model. *Plos One*, 17(3), e0260125. <https://doi.org/10.1371/journal.pone.0260125>
- Weiss, D., & Lang, F. R. (2009). Thinking about my generation: Adaptive effects of a dual age identity in later adulthood. *Psychology and Aging*, 24(3), 729-734. <https://doi.org/10.1037/a0016339>
- Winn, M. I., MacDonald, P., & Zietsma, C. (2008). Managing industry reputation: The dynamic tension between collective and competitive reputation management strategies. *Corporate Reputation Review*, 11(1), 35-55. <https://doi.org/10.1057/crr.2008.4>
- Yong, A. G., & Pearce, S. (2013). A beginner's guide to factor analysis: Focusing on exploratory factor analysis. *Tutorials in Quantitative Methods for Psychology*, 9(2), 79-94. <https://doi.org/10.20982/tqmp.09.2.p079>
- Zainee, I. A., & Puteh, F. (2020). Corporate social responsibility impact on talent retention among generation Y. *Revista de Gestão*, 27(4), 369-392. <https://doi.org/10.1108/REG-06-2019-0070>
- Zhang, Q., Cao, M., Zhang, F., Liu, J., & Li, X. (2020). Effects of corporate social responsibility on customer satisfaction and organizational attractiveness: A signaling perspective. *Business Ethics: A European Review*, 29(1), 20-34. <https://doi.org/10.1111/beer.12243>